

WINGET

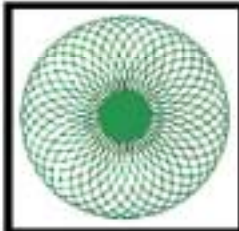

Croker

CUMFLOW RP550XD ROTATING PAN MIXER

PARTS & OPERATION MANUAL

**WINGET LIMITED
PO BOX 41
EDGEFOLD INDUSTRIAL ESTATE
PLODDER LANE
BOLTON
LANCS
BL4 OLS
Tel: ++ 44 (0) 1204 854650
Fax:++ 44 (0) 1204 854663
crokersales@winget.co.uk
parts@winget.co.uk
service@winget.co.uk
www.winget.co.uk**

INDEX

SECTION 1 GENERAL INFORMATION

- 1.1. Company Details
- 1.2. Important Notice
- 1.3. Mixer Operational and Safety Requirements
- 1.4 Installation Drawing
- 1.5 Test Certificates (Where applicable)

SECTION 2 INSTALLATION AND OPERATING INSTRUCTIONS

- 2.1. Pre Installation Notes
- 2.2. Installation Instructions
- 2.3. Operating Instructions

SECTION 3 TECHNICAL SPECIFICATION AND MAINTENANCE

- 3.1. Technical Specification
- 3.2. Shutdown Procedure and Maintenance
- 3.3. Maintenance of Mixer
- 3.4. Maintenance and Lubrication
- 3.5. Lubrication Layout

SECTION 4 MIXER SPARE PARTS

- 4.1. General Arrangement of Parts and Top & Bottom Structures
- 4.2. Pan Roller Assembly
- 4.3. Door Control Assembly
- 4.4. Pan Drive Assembly
- 4.5. Pan Assembly
- 4.6. Pan Door Assembly
- 4.7. Discharge Blade Assembly
- 4.8. Mixing Star Assembly
- 4.9. Fixed Blade Assembly
- 4.10. Layout of Guards
- 4.11. Pan Sealing Arrangement
- 4.12. Decals & Logo's

SECTION 5 OPTIONAL ANCILLIARY EQUIPMENT SPARE PARTS

- 5.1 Arrangement of Winch Unit
- 5.2 Arrangement of Loader Runway
- 5.3 Arrangement Loading Hopper and Weigher
- 5.4 Arrangement of Whirler Motor Up
- 5.5 Arrangement of Whirler Motor Up 460Volt 3Ph 60Hz

5.6	Arrangement of Whirler Split Shaft
5.7	Wire Rope Renewal Procedure
5.8	Wire Rope Safety Notes
5.9	Pneumatic Oiler (Not available on all models)
5.10	Water System
5.11	0-100 Litre Flow Meter
5.12	Bottom Discharge Loading Hopper
5.13	Axle Assembly Bottom Discharge Hopper
5.14	Door Assembly Bottom Discharge Loading Hopper
5.15	Guide Shaft Assembly Bottom Discharge Loading Hopper
5.16	Pulley Bottom Discharge Loading Hopper
5.17	Side Roller Bottom Discharge Loading Hopper
5.18	Loader Frame Bottom Discharge Loading Hopper
5.19	Drive Assembly Bottom Discharge Loading Hopper

SECTION 6 **ELECTRICAL SYSTEM**

6.1	Electrical Instructions
6.2	Wiring Diagrams (Where Applicable)
6.3	Component Listing (Where Applicable)
6.4	Interlock Switch Mounting (Where Applicable)

SECTION 7 **PNEUMATIC SYSTEM**

7.1	Pneumatic Instructions – Shutdown Procedure
7.2	Circuit Diagrams

SECTION 8 **MISCELLANEOUS**

8.1	Noise
8.2	Special Pan Covers and Inlets
8.3	Miscellaneous Items

SECTION 9 **ELECTRONIC LOADCELL & READOUT BOX**

The contents of this handbook although correct at the time of publication, may be subject to alteration by the manufacturers without notice and Winget Limited can accept no responsibility for any errors or omissions contained within the following pages. Nor can we accept any liability whatsoever arising from the use of this manual howsoever caused.

Winget Limited operate a policy of continuous product development. Therefore, some illustrations or text within this publication may differ from your machine

Winget Limited can accept no responsibility for incorrectly supplied spare parts unless the part number and a full description of the items required is given when the order is placed.

NOTE

Imperial fixings (bolts, setscrews, nuts, washers etc) have been progressively changed to Metric. If in doubt as to whether you have a Metric or Imperial fixing please order the metric items listed, i.e. bolt or setscrew and associated or flat and spring washers to replace the existing items.

NOTE

Imperial fixings (bolts, setscrews, nuts, washers etc) have been progressively changed to Metric. If in doubt as to whether you have a Metric or Imperial fixing please order the metric items listed, i.e. bolt or setscrew and associated or flat and spring washers to replace the existing items.

OPERATING
AND
MAINTENANCE MANUAL

SECTION 1

GENERAL INFORMATION

COMPANY DETAILS AND GENERAL INFORMATION

For any spares or service work, please contact:-

Winget Limited
P.O. Box 41
Edgefold Industrial Estate
Plodder Lane
Bolton
Lancs U.K.
BL4 OLS

Telephone No:	++ 44 (0) 1204 854650
Facsimile No:	++ 44 (0) 1204 854663
'E Mail'	crokersales@winget.co.uk parts@winget.co.uk service@winget.co.uk

ORDERING SPARES

To help us to complete your order promptly and correctly we need:-

- Machine type and serial number
- Description and quantity of parts required
- The full address to which the parts are to be sent

Winget Limited can accept no responsibility for incorrectly supplied spare parts unless the part number and a full description of the items required is given when the order is placed.

IMPORTANT NOTICE

The CUMFLOW RP550XD is a high performance mixer

The following precautions are necessary to obtain the best results and to avoid damage to the MIXING STAR and PAN DRIVE

ENSURE TRANSIT BAR AND RING ARE REMOVED FROM DOOR BEFORE STARTING MACHINE.

AGGREGATES

Strict control of graded aggregates must be maintained
Maximum size 25mm

Oversize lumps of aggregate or rogue materials must be prevented from entering the Pan

MIXING STAR BLADES

They are to a special shape and material to prolong wear life. They should not be modified in any way and only replaced with GENUINE 'CROKER' spares Obtained from **WINGET LIMITED**.

A daily check is advisable to ensure that the Blades/Wearing parts are secure and undamaged.

PAN RIM & BASE WEARING PLATES

They must be replaced before excessive wear causes distortion.

MAXIMUM BATCH LOADS

UNDER NO CIRCUMSTANCES should the Maximum Batch Loads quoted be exceeded nor should the mixer be or re-started when there is a mix in the Pan

MIXING PAN

Ensure that the Mixing Pan is rotating concentrically and that the pan base is Rotating in horizontal place, otherwise damage may occur to the door mechanics.

WARNING

THE MANUFACTURER ACCEPTS NO RESPONSIBILITY FOR ANY DAMAGE OR FAILURE RESULTING FROM OPERATIONAL MISUSE OR MALPRACTICE. ANY MODIFICATIONS TO THE MACHINE WILL AFFECT ITS WORKING PARAMETERS AND SAFETY FACTORS. REFER TO THE MANUFACTURERS BEFORE FITTING ANY NON STANDARD EQUIPMENT OR PARTS.

THE MANUFACTURERS ACCEPT NO RESPONSIBILITY FOR ANY MODIFICATIONS MADE AFTER THE MACHINE HAS LEFT THE FACTORY, UNLESS PREVIOUSLY AGREED IN WRITING. THE MANUFACTURERS WILL ACCEPT NO LIABILITY FOR DAMAGE TO PROPERTY, PERSONNEL OR THE MACHINE IF FAILURE IS BROUGHT ABOUT DUE TO SUCH MODIFICATIONS, OR THE FITMENT OF SPURIOUS PARTS.

RP550XD
OPERATIONAL AND SAFETY
REQUIREMENTS

PRE-DELIVERY

- 1.1 Drive coupling alignments, pan and star meshing of pan rack and drive gear.
- 1.2 Operating clearances star blade to pan. Fixed blade to pan wall.
- 1.3 Discharge blade to pan base.
- 1.4 Rollers to register ring.
- 1.5 Correct oil level in gearboxes. All grease points charged. Gear teeth greased.
- 1.6 Air system tested.
- 1.7 Door operation and seating.
- 1.8 No load test. Correct rotations.

PRE INSTALLATION

- 2.1 Check consignment.
- 2.2 Offload equipment using certified lifting gear of suitable capacity, by a competent person (see separate chart for nett weight).

INSTALLATION

- 3.1 Refer to contract arrangement and site instructions.
- 3.2 Mixer to be mounted on supports of adequate strength and rigidity to prevent undue vibration when mixing and securely bolted.
- 3.3 Mixer frame to be level on structure, add packers as required.
- 3.4 Check that pan is correctly seated on Rollers and that pan rack and drive gear are in correct mesh.
- 3.5 Check locating rollers to register ring.
- 3.6 Check operating clearances star blade to pan. Fixed blade to pan wall. Discharge blade to pan base. See maintenance section Ops Manual.

ELECTRICAL SERVICES

- 4.1 Refer to wiring diagrams in Section 6. All wiring to be undertaken by competent electrician.
- 4.2 Refer to pneumatic circuit diagram in Section 7. Connect compressor. Supply compressed air 5.5 bars as required (80psi).
- 4.3 Refer to wiring diagram in Section 6 when connecting air control valves.
- 4.4 Remove transit bar and ring from door BEFORE starting mixer.
- 4.5 Ensure starters are mounted away from mixer on supports free of vibration.
- 4.6 Ensure starters are fitted with correct overloads – see technical specification power units.

OPERATION

- 5.1 Correct oil level, gearboxes. Air line lubricator.
- 5.2 Mixing pan clear of loose nuts and bolts to prevent damage to fingers and blades.
- 5.3 Check correct rotation – mixing star – anti clockwise; mixing pan – anti clockwise. All when viewed from the top.
- 5.4 Discharge door and blade correct operation.
- 5.5 Blade operating clearances adjust in line with maintenance instructions.
- 5.6 Never exceed manufacturer's maximum capacity as detailed in specification.

SHUTDOWN

- 6.1 Prior to any work being carried out mixer to be isolated and physically locked off. Recommended equipment double key exchange system.
- 6.2 Follow procedure detailed in company and users' Health and Safety Policy at all times.
- 6.2 Ensure all storage bins containing materials to be mixed are isolated.
- 6.3 Shut off water supply and drain off water tank or flowmeter

MAINTENANCE

- 7.1 Ensure that all maintenance is carried out in accordance with the Parts and Operating manuals and proprietary manufacturer's specific instruction.
- 7.2 Isolate electrical and other services to the mixer as section 6 above.
- 7.3 Service at recommended intervals.
- 7.4 Use Croker manufactured replacement parts supplied by **WINGET LIMITED**.

GENERAL

- 8.1 Under no circumstances should the Maximum Batch Loads be exceeded by either weight and volume as stated in Technical Specification.
- 8.2 Mixer star blades to be checked daily for damage.
- 8.3 Pan rim and base wearing plates must be replaced before excessive wear causes distortion.
- 8.4 Ensure mixing pan is rotating concentrically and pan base is rotating in horizontal plane.
- 8.5 Mixer must not be stopped and started when there is mix in the pan.
- 8.6 Refer to Contract Drawing for scope of supply. Site instruction notes outlining weights etc.
- 8.7 Refer to Method Statement when installation and commissioning is responsibility of Winget Limited.

Nett Weights Max (kgs)

9.1	RP50XD	788	RP1250XD	4840
	RP100XD	814	RP1500XD	4980
	RP200XD	1400	RP3000XD	7112
	RP400XD	2000	FP1000	4040
	RP550XD	2150	FP1500	4065
	RP850XD	2600	FP2000	4100

- 9.2 Refer to technical specification for nett weights of ancillary equipment.
- 9.3 Refer to contract drawing for nett weights of ancillary equipment.

Miscellaneous

10.1 Noise measured in accordance with Directive 79/113 EEC 85LPA.

RP550XD GENERAL ARRANGEMENT BASIC MACHINE

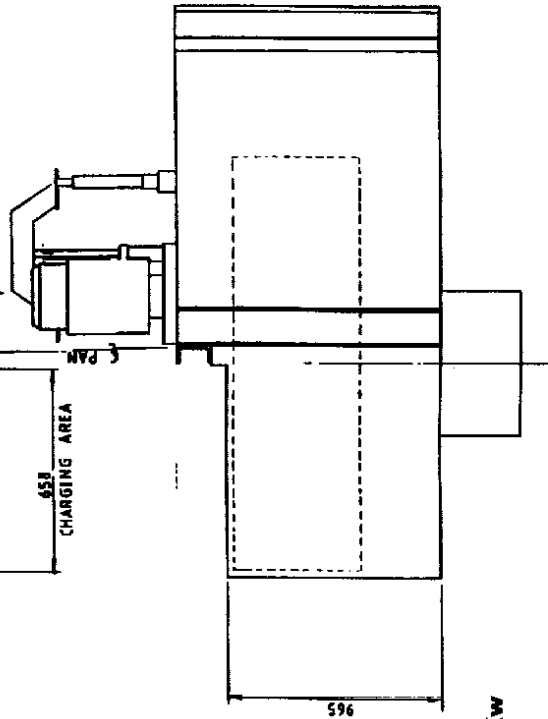
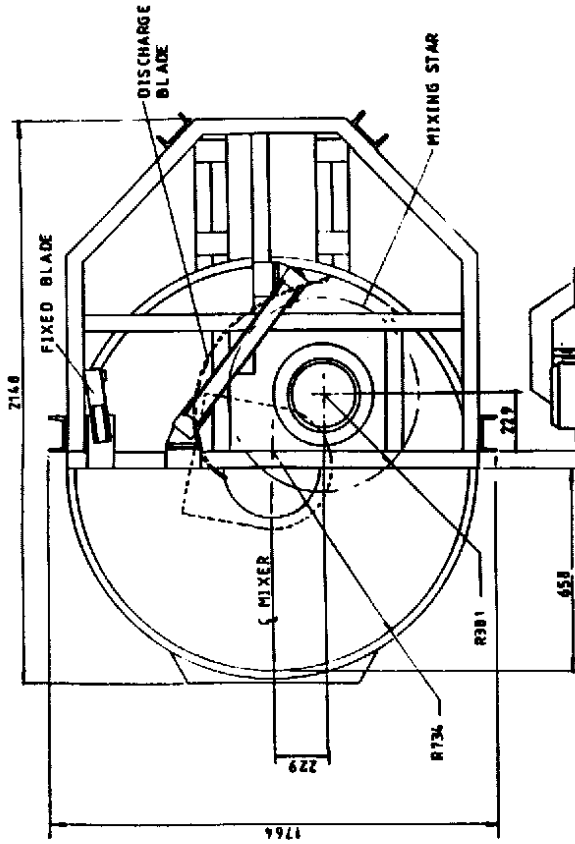
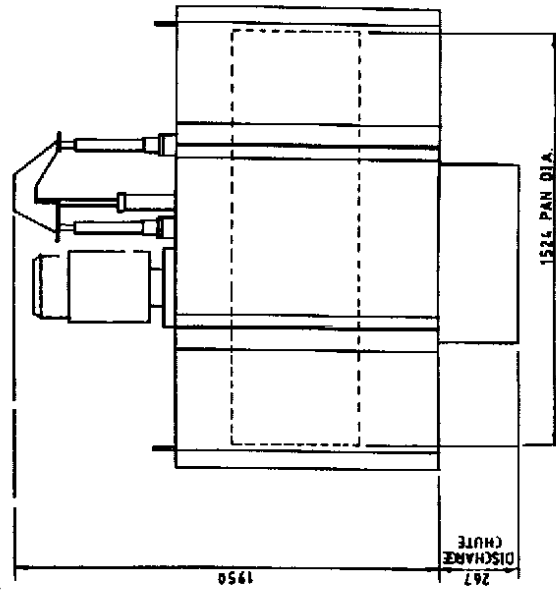
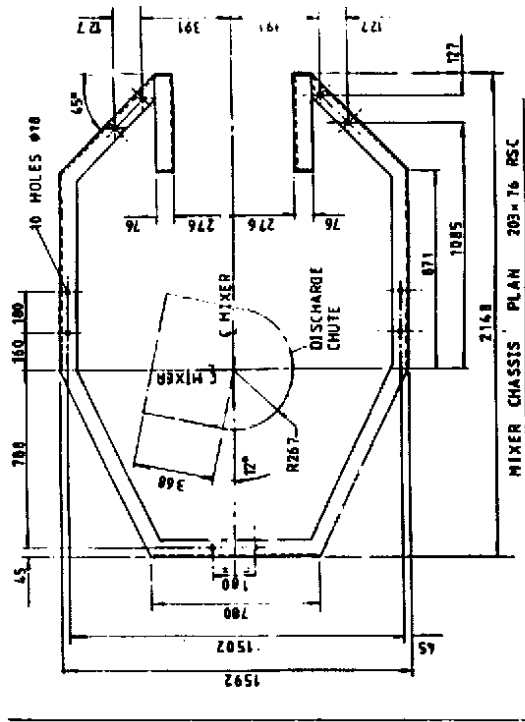

**MIXING STAR 11Kw
PAN DRIVE 2.2Kw
MIXER MUST BE INSTALLED WITH
SAFETY GUARDS**

RP550XD GENERAL ARRANGEMENT WITH WHIRLER

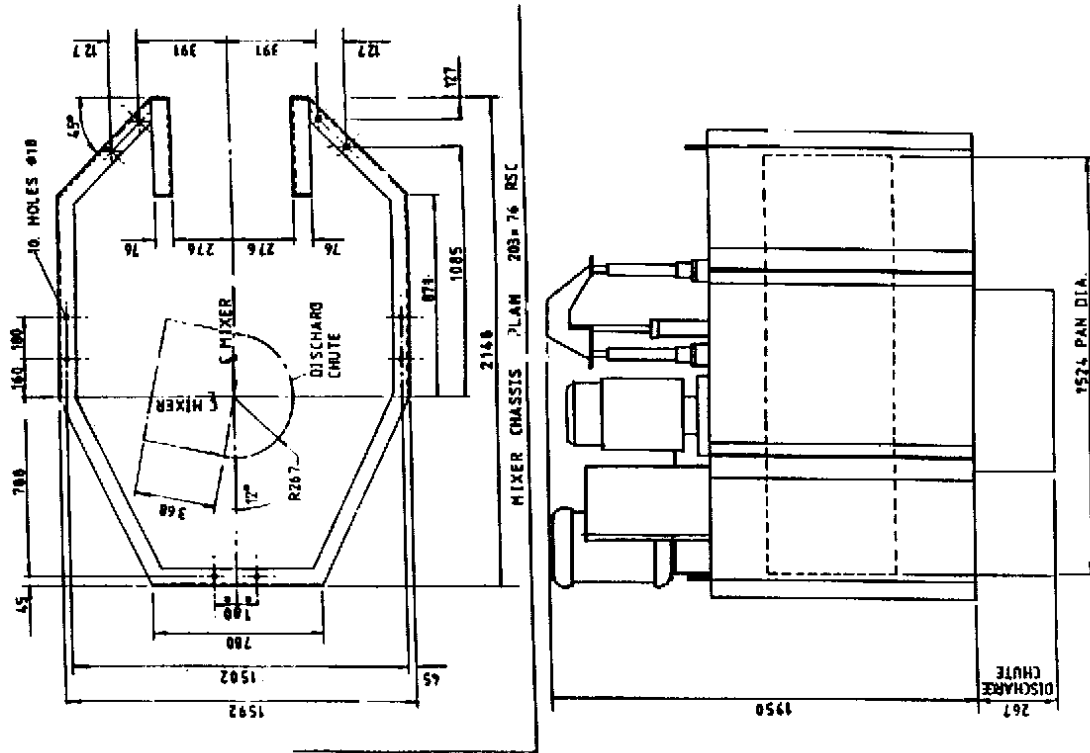

**MIXING STAR 11KW
 PAN DRIVE 2.2KW
 WHIRLER 15KW
 MIXER MUST BE INSTALLED WITH
 SAFETY GUARDS FITTED**

RP550XD GENERAL ARRANGEMENT WITH LOADER

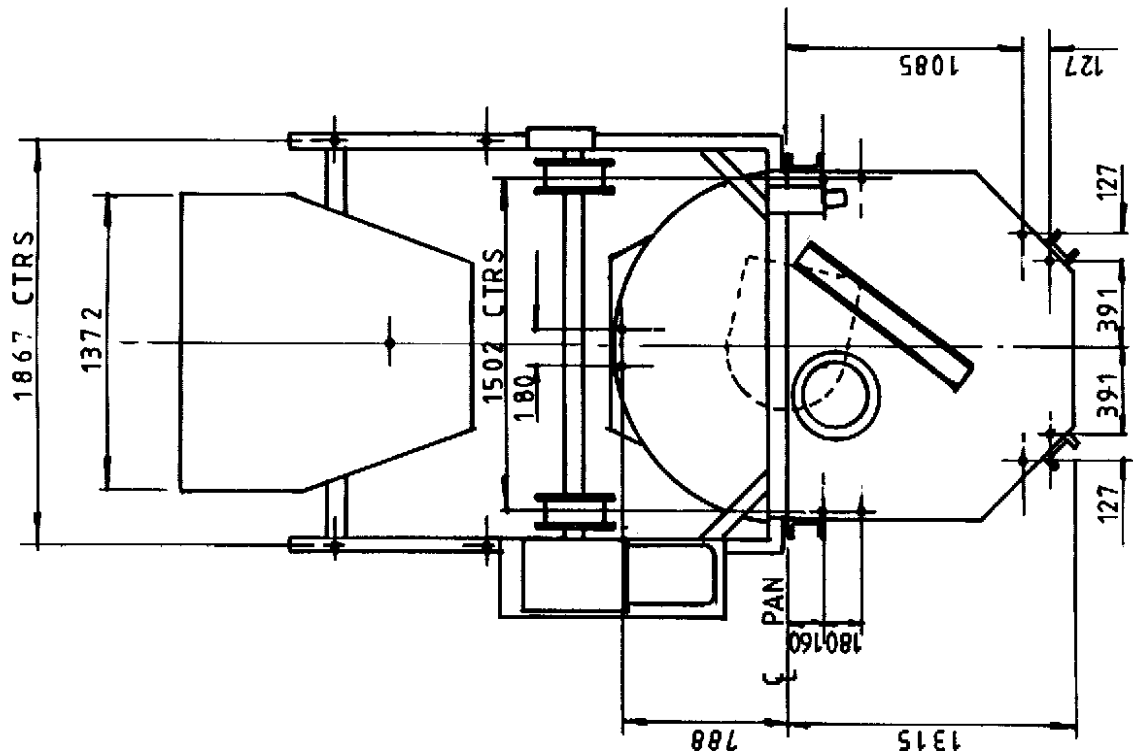
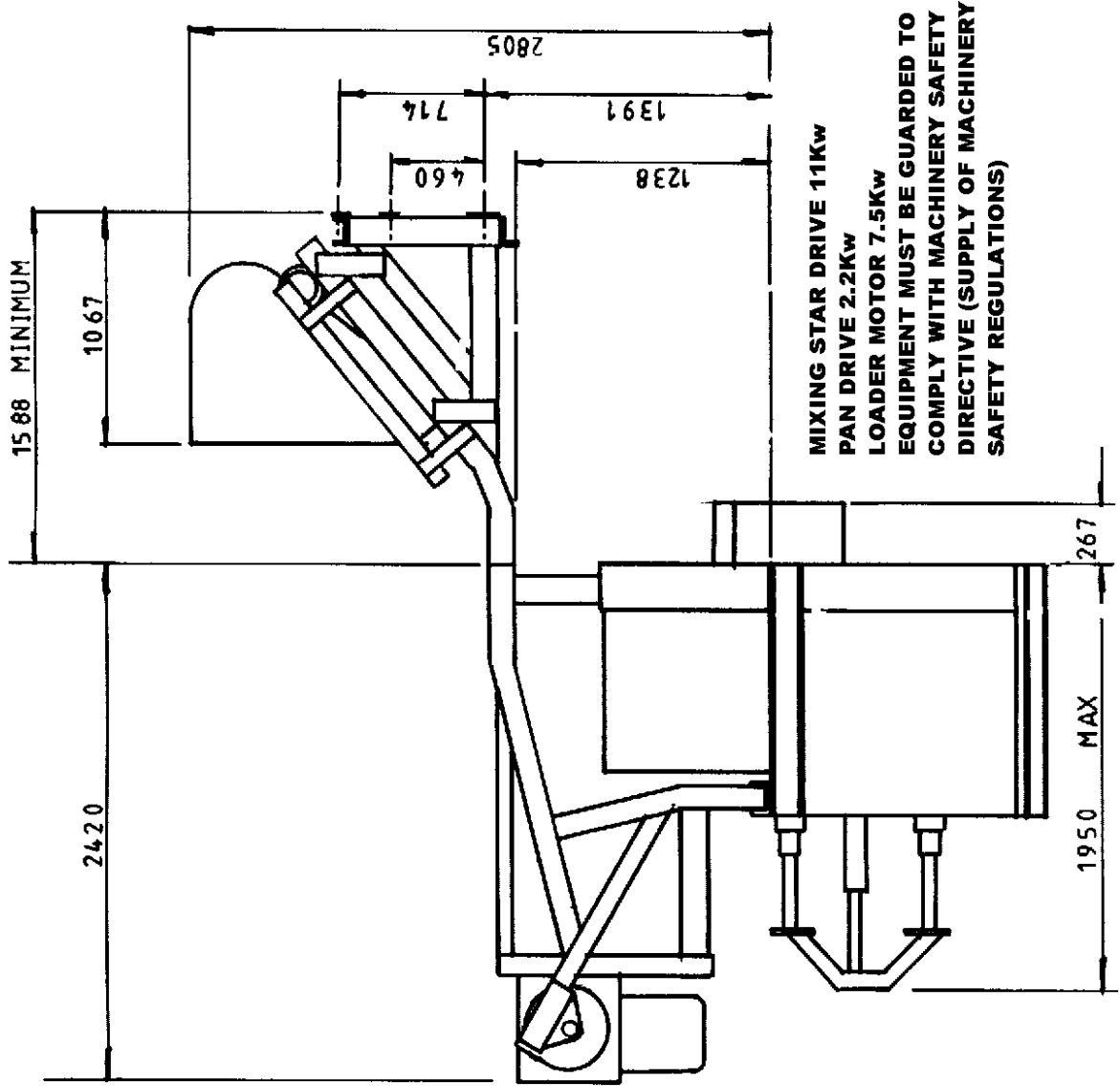

RP550XD ARRANGEMENT OF BOTTOM DISCHARGE LOADING HOPPER

- 1 CR089045 L/HOPPER ASSEMBLY**
- 2 CR089046 L/FRAME ASSEMBLY**
- 3 CR089047 L/DRIVE ASSEMBLY**

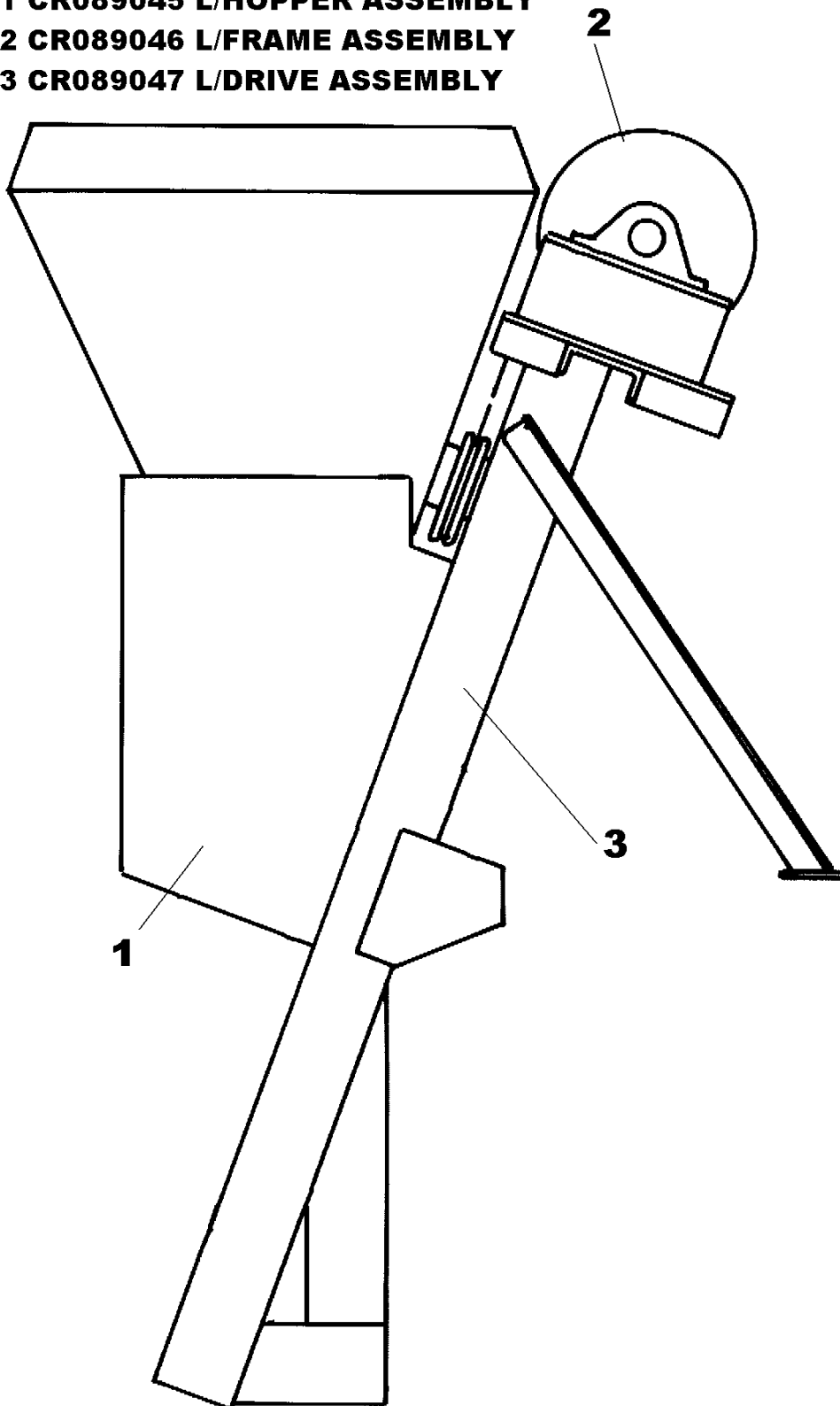

**OPERATING
AND
MAINTENANCE MANUAL**

SECTION 2

**INSTALLATION AND OPERATING
INSTRUCTIONS**

PRE-INSTALLATION

On arrival of the equipment it is advisable to check that all packages listed on the consignment note have been received.

The equipment must be offloaded using certified lifting gear of suitable capacity, by a competent person.

When unloading the mixer, care must be taken to ensure the discharge chute remains clear of obstructions as the chute and door hang below the chassis.

An outline drawing and bolt hold plan is normally sent prior to the despatch of the machine and will enable preparations to be made for the installation. With the `picture` of what the machine will look like when it is assembled, the ancillary equipment dismantled for transport can easily be identified.

INSTALLATION

Please refer to contract arrangement and site instructions as applicable.

It is recommended that a concrete foundation (to take foundation bolts – not supplied) should be provided for each leg of the support structure and runway when fitted. When the machine is supplied without a support structure it should be mounted on supports of sufficient strength and rigidity to prevent undue vibration when the machine is working. When making provision for a loading hopper pit it is strongly recommended that the pit is concreted out so that it can easily be kept clean and free from any build up which could prevent the bottom limit switch from operating correctly.

Before completing the installation, check that the main mixer frame is level with a spirit level. Packings should be inserted as required under the structure legs or main frame. The packings under the mixing pan roller brackets are set during manufacturing and must not be disturbed under any circumstances.

Check that the pan is seated and that the pan rack and drive gear are in mesh.. Also check that all the blade clearances are in line with the maintenance instructions.

On connecting to the power supply, the wiring diagram must be referred to. A check that the wiring is correct is rotation of the following:-

- The mixing pan and mixing star rotate anti-clockwise when looking from the top.
- The loader winch rotates anti-clockwise looking from the rope drum end and when the raise button is pressed.
- The whirler unit rotates clockwise when looking from the top.

It is advisable to mount the starters away from the machine on supports free from vibration. Ensure that the starters are fitted with suitable overloads – see technical specification – power units.

A simple Water Flow Meter is available as an option to the water tank, this has a range of 0-100 litres and features an adjustable flow indicator with a reset facility allowing very accurate measurement of water flow irrespective of the pressure. The Flow Meter is normally fitted with a manual ‘on/off’ valve and is protected by a washable in line strainer.

A supply of compressed air at 5.5 bars is required. The inlet for the connection from the air line is tapped ½” B.S.P. A drop in pressure will cause incorrect operation of the pneumatic system.

OPERATING THE MACHINE

Before starting production the following points should be checked:-

- (1) That there is oil in
 - (a) the Star Drive Gearbox
 - (b) the Pan Drive Gearbox
 - (c) the Loader Winch Gearbox (when fitted)
 - (d) the Air Line lubricator
- (2) The Mixing pan should be clear of loose nuts, bolts, spanners etc., as these will damage the fingers and blades.
- (3) Check that the Discharge Door and Discharge Blade are operating correctly.
- (4) Check that the blade clearances are correct and if necessary adjust, in line with the maintenance instructions.
- (5) Check that the limit switches on the loader stop the Loading Hopper in the required positions at the top and bottom of the runway and that the magnetic brake is applied.
- (6) Check that the Water tank is set to the required amount and is filling up to this level. (See later page for further information on Water Tank operation).
- (7) If a Flow Meter is fitted check that the pointer is reset to zero and the strainer is clean and free from debris.
- (8)** When Weigh Gear is fitted check that the setting arrangements and any lubrication requirements have been carried out. .

IMPORTANT:

The CUMFLOW is a high performance Mixer.

The following precautions are necessary to obtain the best results and to avoid damage to the Mixing Star and Drive.

AGGREGATES:

Strict control of graded aggregates must be maintained. Maximum Size 25mm.

Oversize lumps of aggregate or rogue material must be prevented from entering the Pan.

MIXING STAR BLADES:

They are of a special shape and material to prolong wear life. They should not be modified in any way and only replaced by genuine ‘**WINGET CROKER**’ spares.

Daily check is advised to ensure that the Blades/Wearing Pieces are securely bolted and undamaged.

PAN RIM & BASE WEARING PLATES:

They must be replaced before excessive wear causes distortion.

MAXIMUM BATCH LOADS:

Under no circumstances should the Maximum Batch Loads quoted be exceeded nor should the Mixer be stopped and re-started when there is a mix in the Pan.

After each mix the contents of the pan must be completely discharged before attempting to close the discharge door. At the end of each period of operation the mixing pan, mixing blades, discharge blade and fingers, discharge chute, discharge door and seating must be washed down to prevent concrete setting on them and so impairing the efficiency of the machine.

WARNING:

THE MAUFACTURER ACCEPTS NO RESPONSIBILITY FOR ANY DAMAGE OR FAILURE RESULTING FROM OPERATIONAL MIS-USE OR MALPRACTICE.

OPERATING INSTRUCTIONS FOR WEIGH GEAR MECHANISM

HYDROSTATIC LOADCELL & GAUGE

The Hydrostatic Load Cell is connected by a flexible capillary tube (approx 9.7 metres long) to a 300mm (12”) diameter weigh gauge.

The whole system is assembled and filled with fluid under vacuum and under no circumstances should any of the components be disconnected, in the event of component damage the complete assembly should be returned to Winget Limited for repair.

The system is factory calibrated and any variation between the calculated tare and the actual tare recorded can be corrected by means of the tare adjustment knob on the side of the gauge.

With no load acting on the loadcell the pointer will be below zero, this is to accommodate the weight of the hopper. When the hopper is placed on to the loadcell the pointer will register zero. Final zero adjustment can be made via the zero adjustment knob on the side of the gauge housing.

ELECTRONIC LOADCELL & GAUGE

The electronic Loadcell & Gauge consists of an electrically operated loadcell mounted on the weigher frame and connected to a remote mounted digital readout control box. The connecting lead should be protected from damage and the readout box mounted such that it is not affected by vibrations etc. The mounting instructions detailed within Section 9 of this manual should be followed to avoid excess vibrations damaging the control box. Section 9 also contains detailed advice on setting up, obtaining zero and operation of the loadcell and readout box and should be referred to before the equipment is operated.

NOTE THE FOLLOWING WIRING CONNECTIONS

- + Excite RED
- Excite BLUE

- + Signal GREEN
- Signal YELLOW

OPERATING INSTRUCTIONS FOR 0-100 LITRE WATER FLOWMETER

The simple manually operated 0-100 litre Water Flow Meter is available as an option to the water tank and is normally mounted on the side of the mixer feeding directly into the pan. The meter is normally fitted with 1" hose tail connectors but different sizes of water inlet connections to suit various hose diameters are also available. The meter is normally provided with a simple 'on/off' valve and inline filter/strainer mounted next to but down stream of the flowmeter.

OPERATION

On a daily basis before use the strainer should be removed and checked for debris and obstructions, cleaned and refitted. Ensure the on/off valve is in the 'off ' position and turn on the main water supply. Set the adjustable pointer on the dial face via the central knob to the required amount of water. Check the indicator reads zero, if not operate the reset lever on the side of the meter which will reset the indicator. Turn the on/off valve slowly to the 'on' position watching the movement of the indicator around the dial, when the indicator reaches the pointer sharply turn valve to the 'off ' position. The indicator will register the amount of water delivered. Operate the reset lever to bring the indicator back to zero and repeat the operation for each batch of material mixed.

When shutting down the mixer either at night or at the end of each shift it is recommended that the main water supply to the flow meter and 'on/off' valve is shut off.

If it is expected that the overnight temperatures will drop to or close to freezing it is recommended that the Flow Meter, Valve, Filter and Pipework are drained to prevent damage.

OPERATING THE MIXER

SAFETY NOTES

Never operate the mixer unless you have read and fully understand the contents of the Operators Manual

Never operate the mixer whilst wearing loose fitting clothing

Never reach inside the Pan whilst it is rotating

Never operate any equipment unless you have received adequate training

Cement, certain other minerals and organic compounds can cause skin irritation leading to Dermatitis. Always use Personal Protective Equipment i.e. gloves etc to protect the skin from direct contact. If in any doubt about the materials being used consult your employers COSHH manual

Wear Eye protection to protect your eyes from dust and liquid splashes

Do not attempt to remove the pan single handedly, obtain assistance, use the Pan Trolley (if provided) or use suitable lifting equipment

Do not operate the mixer with any of the guards removed, safety devices or interlocks disconnected. They are there to offer you some protection, ensure they are correctly maintained

Carry out the daily maintenance before operating the mixer and report defects to your supervisors

Oils, Greases and Lubricants are skin irritants and prolonged direct skin contact can cause skin cancer. PPE or barrier creams should be used when carrying out maintenance work, wash your hands on completion

Always dispose of waste oils and lubricants in a proper manner, it is illegal to pour it down drains or bury it. Contact your local authority for a list of authorised disposal sites

Always disconnect the power supply at the mains before carrying out any maintenance work or cleaning the equipment down. Do not turn on the power until everything has dried out

Do not allow waste from the wash down process to enter the public drainage system unless it has been properly filtered.

Decals and Instruction Plates are attached to the equipment to warn against hazards and assist in the safe operation of the equipment, if damaged or defaced they should always be replaced.

It is likely that clutch and/or brake linings may contain asbestos and suitable precautions should be taken to avoid breathing in the dust, protective clothing should be worn. Hands should be washed immediately after handling components and old discarded parts or linings should be disposed of in a responsible manner in line with local or national regulations covering the disposal of asbestos waste.

**OPERATING
AND
MAINTENANCE MANUAL**

SECTION 3

**TECHNICAL SPECIFICATION
AND MAINTENANCE**

TECHNICAL SPECIFICATION OF CUMFLOW RP550XD

<u>CAPACITIES:</u>	Maximum Batch Capacity	by Weight	820 kgs
		by Volume	550 litres
	Nominal Output (based on 2.42kg/lt)		360 litres
	Nominal Output (based on 2.162kg/lt)		400 litres
	Hourly Output		13.6cu.m

<u>AGGREGATES:</u>	Maximum Aggregate Size	25 mm
---------------------------	------------------------	-------

<u>MIXER FRAME:</u>	Strongly constructed from welded Steel Channel
----------------------------	--

<u>MIXING PAN:</u>	Steel Base Pan mounted on three wide track rollers with central discharge door. Pan Rim, Base and Discharge Door fitted with renewable Wearing Plates.
---------------------------	--

<u>MIXING STAR:</u>	Twin Arm Mounting, Four Spring loaded Star Blades, Two at Pan floor level and Two for high level mixing.
----------------------------	--

<u>FIXED BLADE:</u>	Spring loaded pan side scraper assembly. Reversible when worn
----------------------------	---

<u>DISCHARGE BLADE:</u>	Pneumatically operated in conjunction with the Discharge Door.
--------------------------------	--

<u>WHIRLER:</u>	Intermittent blades mounted on vertical shaft.
------------------------	--

<u>POWER UNITS:</u>	Mixing Star)	11.0 kw
	Mixing Pan)	2.2 kw
	Loader Motor (where fitted)	7.5kw
	Whirler Motor (where fitted)	15 kw

<u>DRIVES</u>	Mixing Pan	Gear unit with pinion and cast rack
	Mixing Star	Gear unit directly mounted
	Whirler	Vee Rope Drive

<u>SPEEDS</u>	Speed of Pan	12 rpm
	Speed of Mixing Star	57 rpm
	Speed of Loading Hopper	21 metres/min
	Speed of Whirler	720 rpm

<u>FREE AIR CONSUMPTION (PER BATCH 80 PSI)</u>	63.7 litres
---	-------------

<u>WEIGHTS (UNLADEN)</u>	Without Loader	2150 kg
	With Loader (approx)	3275 kg

<u>ELECTRICS</u>	Motor Voltage	415V 3ph 50hz Option 60 hz
	Control Voltage	110V

MACHINE SAFETY DIRECTIVE

All Gears are suitably guarded.

MAINTENANCE

IMPORTANT

ALWAYS ENSURE APPARATUS IS ISOLATED FROM MAINS SUPPLY BEFORE COMMENCING MAINTENANCE.

SHUTDOWN PROCEDURE

Prior to any work being carried out the apparatus is to be isolated and physically locked off.

We recommend a double key exchange system.

Safe access to equipment with one access door and one control point.

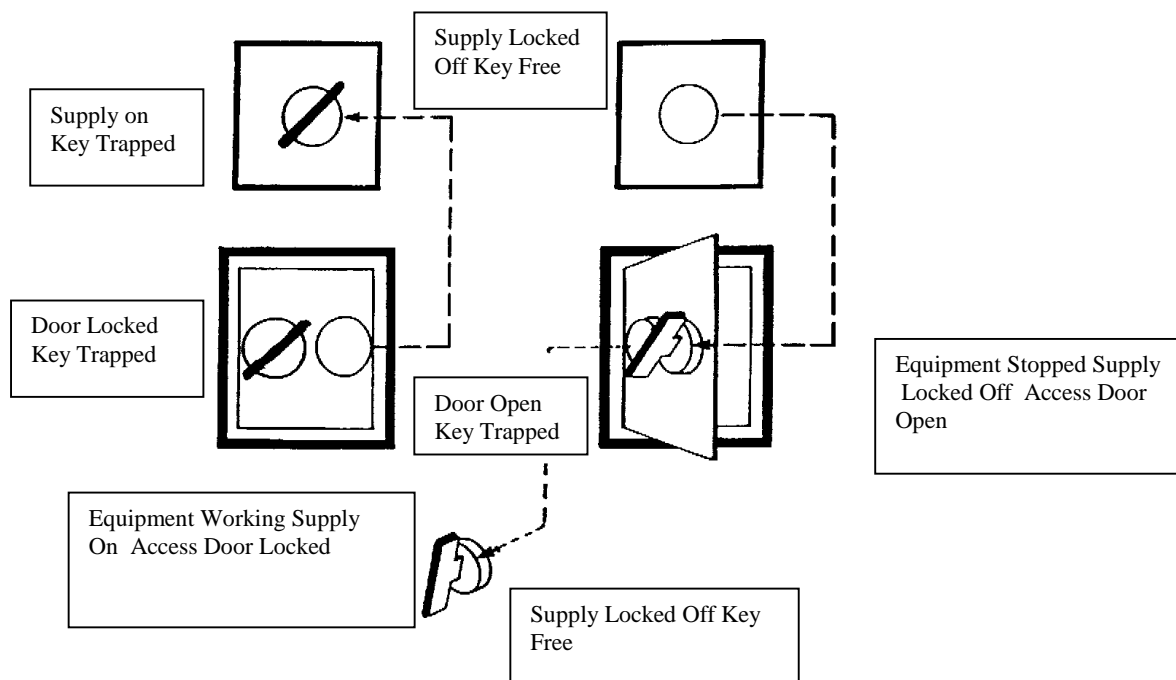

Follow the procedures detailed in your Health and Safety Policy at all times.

Ensure all storage bins containing materials to be mixed are isolated.

Shut down the water supply and drain off any water tanks or flowmeter fitted

MAINTENANCE OF MIXER

IMPORTANT NOTE:

Ensure that all maintenance is carried out in accordance with the Parts and Operating Manual and Proprietary Manufacturer's specific instruction.

PROCEDURE

- 1 ISOLATE ELECTRICAL, PNEUMATIC AND OTHER SERVICES TO THE MIXER (see separate section).
- 2 Service at recommended intervals.
- 3 Use Croker manufactured replacement parts available from **WINGET LIMITED**.
- 4 Ensure all safety guards and interlocks are reinstated prior to operating the mixer.
- 5 Main items of wear (see Section 4).
 - A) Star Blades
 - B) Fixed Blade
 - C) Discharge Blade
 - D) Whirler Blades

Access to mixing pan internals is via the safety interlocks. Each of the above are bolted components and are replaced by simple method and usually achieved in situ without dismantling other components.

- E) Pan base and rim wearing plates are also bolted construction and can be replaced in situ. However, pan covers will need to be dismantled to provide the necessary access.
- F) Other items prone to less wear are star blade fingers, lower whirler shaft assembly and mixing star. Each can be replaced again in situ but pan covers would require dismantling to provide necessary access.
- G) Pan rollers can be adjusted to accommodate wear during operation. These can be replaced when required in situ using jacking method to support pan and provide the necessary access.

MAINTENANCE AND LUBRICATION

DAILY: Using Total Multis EP2 Grease 2 (or equivalent) grease the following points:-

Pan Roller Spindles	3 Points
Discharge Blade Lifting Gear Brackets	2 Points
Air Cylinder Lever Pivot Holder	1 Point
Mixing Blade Finger Bearings	2 Points
Fixed Blade Finger Bearing	1 Point
Loading Hopper Rollers	2 Points
Pan Drive Plummer Bearings	2 Points
Loader Rollers (Where fitted)	4 Points
Whirler (Where Fitted)	2 Points

Inspect and top-up if necessary:-

Air Line Lubricator

Use Total Azolla 27 (or equivalent)
or suitable Pneumatic Tool Oil.

WEEKLY: Inspect and top up if necessary:-

(1) **Star Drive Gearbox (Capacities Approximate)**

RENOLD UNITS

Cap 23.8 litres. Use Total Carter EP320
or Shell Omala 320 or equivalent.

FLENDER UNITS

Cap 17.5 litres. Use Total Carter EP220
or Shell Omala 220 or equivalent.

SEVER UNITS

Cap 20.0 litres. Use Total Carter EP220
or Shell Omala 220 or equivalent.

(2) **Pan Drive Gear Box Capacities Approximate)**

RENOLD UNITS

Cap 4.0 litres. Renold Pan Drives must
be run on a synthetic not a mineral oil.
Use Total Carter EPHT320 or Total
Carter SY320 or Mobil Synthetic
SHC632 or equivalent synthetic oils. The
different synthetic oils will not mix with
each other so the Gearbox must be
drained and flushed prior to topping up
or refilling with a different make of oil..

FLENDER UNITS

Cap 3.50 litres. Flender Pan Drives must be run on a synthetic not a mineral oil. Use Total Carter EPHT460 or Total Carter SY460 or Tribol 800 iso460 or B.P. Eersin SG-XP460 or equivalent synthetic oils. The different synthetic oils will not mix with each other so the Gearbox must be drained and flushed prior to topping up or refilling with a different make of oil..

SEVER UNITS

Cap 4.1 litres. Sever Pan Drives must be run on a synthetic not a mineral oil. Use Total Carter EPHT460 or Total Carter SY460 or Tribol 800 iso460 or B.P. Eersin SG-XP460 or Castrol Alphasyn PG680 or equivalent synthetic oils. The different synthetic oils will not mix with each other so the Gearbox must be drained and flushed prior to topping up or refilling with a different make of oil..

(3) Loader Winch Gearbox (Flender)

Cap 5.0 litres. Use Total Carter EP220 or Shell Omala 220 or equivalent.

Inspect and Adjust

- (1) Pan Gear and Pinion – Apply Open Gear Lubricant (or equivalent) as required.
- (2) Adjust Star Blades, Fixed Blades and Discharge Blade to the following settings, also make sure that Blade fingers are free in their bearings and that the springs are clear of obstructions.

Mixing Blade: (3 mm) clear of pan base. Adjust by moving the blade down its finger.

Discharge Blade: Just touching pan base when finger bridge is resting on stop sleeves. Adjust by moving bridge up or down fingers.

Fixed Blade: (3 mm) clear of pan base and just touching pan rim. Adjust by moving hinge brackets along its slots and blade up or down its fingers. Re-set spring to 100 mm overall length after setting blade.

- (3) After the first week's running the Whirler Vee Belt Drive will need adjustment to take up initial wear and stretch. At the correct tension it should be just possible to twist each belt through 90° when gripped between finger and thumb midway between pulleys.
- (4) Loading Hopper Wire Rope – clean off grit etc. and inspect for broken strands. Clean and apply a suitable wire rope dressing.

500 HOUR MAINTENANCE FOR PAN AND STAR DRIVE GEAR UNITS

After 500 running tours, the Gearboxes should be drained and thoroughly flushed with a light flushing oil and refilled with new oil of the correct grade listed below. It is advisable to drain, flush and refill with new oil after every 12 months, or more often if operating conditions are severe.

To fill the Gearboxes, remove the oil level plug and the filler breather plug and pour in oil until it flows from the level hole. Replace the plugs making sure that the vent holes in the filler breather plug are clear. Refer to the following notes.

RENOLD UNITS

Capacity of Star Gearbox: (approximate) 23.8 litres

Use Total Carter EP320 or Shell Omala 320 or equivalent

Capacity of Pan Gearbox: (approximate) 4.0 litres

The Renold Pan Drives must be run on a synthetic oil not a mineral. Use Total Carter EPHT320 or Total Carter SY320 or Mobil SHC632 (Synthetic Oils). The different synthetic oils will not mix with each other so the gearbox must be drained and flushed prior to topping up or refilling with a different make of oil.

FLENDER UNITS

Capacity of Star Gearbox (approximate) 17.5 Litres

Use Total Carter EP220 or Shell Omala 220 or equivalent.

Capacity of Pan Gearbox (approximate) 3.50 Litres

The Flender Pan Drives must be run on a synthetic oil not a mineral. Use Total Carter EPHT460 or Total Carter SY460 or Tribol 800-ISO460 or B.P. Enersin SG-XP460 (Synthetic Oils). The different synthetic oils will not mix with each other so the gearbox must be drained and flushed prior to topping up or refilling with a different make of oil.

SEVER UNITS

Capacity of Star Gearbox (approximate) 20.0 Litres

Use Total Carter EP220 or Shell Omala 220 or equivalent.

Capacity of Pan Gearbox (approximate) 4.01 Litres

The Sever Pan Drives must be run on a synthetic oil not a mineral. Use Total Carter EPHT460 or Total Carter SY460 or Tribol 800 iso460 or B.P. Enersin SG-XP460 or Castrol Alphasyn PG680 or equivalent synthetic oil. The different synthetic oils will not mix with each other so the gearbox must be drained and flushed prior to topping up or refilling with a different make of oil.

MONTHLY: Inspect:

- (1) All blades for wear – replace when worn.
- (2) Pan rim, base and door wear plates – replace when worn
- (3) Pan Roller Bearings – replace if necessary
- (4) Pan Door Bearing – replace if necessary
- (5) Pneumatic system for leaks – repair or replace damaged parts.
- (6) Pneumatic Cylinders. Make sure that the door cylinder piston rod is at the end of its travel when the discharge door is just home in its seating.
- (7) Check the S.H. bushing securing the Mixing Star and Pan Drive to their respective gearbox shafts are tight. Torque setting 34 nm.

CAUTION: BEFORE WORKING UNDER LOADING HOPPER, REST HOPPER ON SAFETY BOLTS. DO NOT FORGET TO REMOVE THESE BOLTS BEFORE RE-STARTING THE MACHINE

(Item 45 on arrangement of Loader Section)

- (8) Loader Magnetic Brake – adjust if necessary, to the following instructions (these instructions apply only if a separate brake unit is fitted, refer to the manufacturer if a combined motor and brake unit is fitted):-

Mounting:

Set the brake so that the horizontal centre-line of the shoe corresponds with the centre-line of the brake wheel shaft and the shoe pivots are equally spaced from the vertical centre-line.

Installing:

Slacken back equalising screw (Item 14) Slack nut (Item 5) and adjust screw (Item 3) to give required braking torque.

WARNING:

The end of the adjusting screw (Item 3) must always be visible in the hole at the end of the adjusting nut (Item 6).

Set nuts (Item 5) so that contact is made with the load spring block in the shoe lever when solenoid plunger has moved through half its stroke. Once properly set, this setting should not be altered. With solenoid plunger right down, set equalising screw (Item 14) to give equal friction lining clearances.

Tighten locknuts (Item 5 & Item 14) and be sure that the load spring bracket is in place.

Check adjustments frequently and lubricate brake shoe pivots. To adjust for wear, screw in adjusting screw (Item 3) until the adjusting nuts are clear and only touch lever (Item 1) when plunger is depressed through half its stroke.

When new linings are fitted, repeat all adjustments.

Orders and enquiries should always state full description of parts required together with the make and model of brake and motor. The serial number on the brake should always be quoted and when ordering replacement brake shoes give the dimensions and number of rivet holes.

Check that the limit switch on the loader stops the hopper in the required position at the top of the runway.

When operated the limit switch should stop the motor and apply the magnetic brake unit.

If a Batch Weigher is not to be used in conjunction with the Loader, then the skip track must be extended and a lower limit switch and hopper stops incorporated.

The loading hopper must operate the lower limit switch before the hopper stops are reached and allowance made for the rope to slacken once the hopper is in the loading position.

ANNUALLY:

Loader Winch Gear Box (Flender):

Drain and clean out the gear case and refill with Total Carter EP220 or Shell Omala 220 or equivalent. When running conditions are severe this procedure should be adopted more frequently. Approximate Capacity 5 litres.

NOTE

Electrical cables particularly those with copper conductors suffer from a condition known as 'relaxation' which may cause wiring to work loose over a period of time, it is recommended that the tightness of wiring connections and terminals are checked following the first month in service.

LUBRICATION LAYOUT

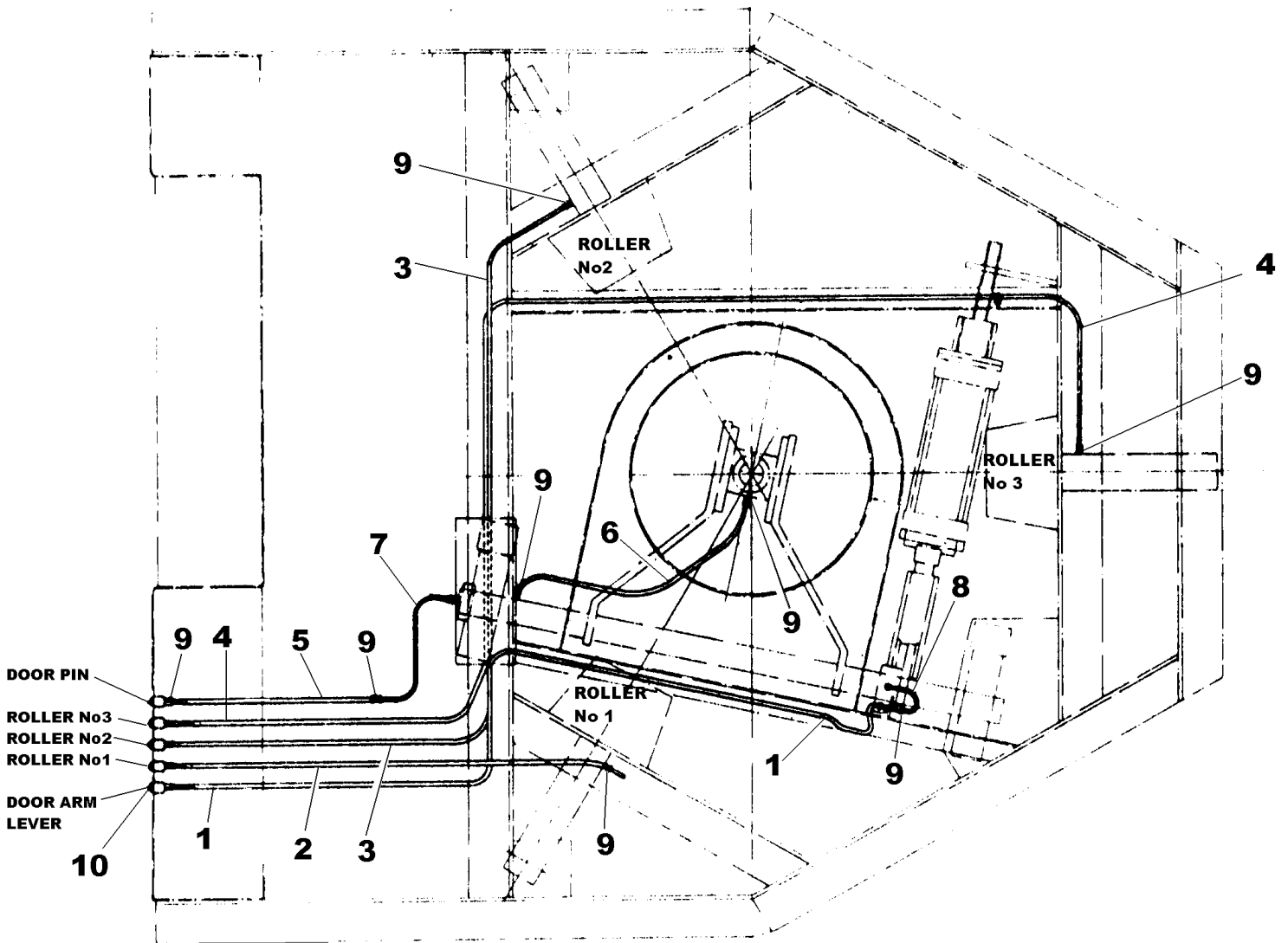

LUBRICATION LAYOUT

<u>ITEM</u>	<u>PART NO.</u>	<u>DESCRIPTION</u>	
1		Lubrication Panel	1
2	131S01	Grease Nipple	7
3	CR510012	Straight Connector	7
4	CR289006	Straight Connector	A/R
5	CR289004	Tube Nut	A/R
6	CR269007	Tube Olive	A/R
7	CR510415	Bundy Tube	A/R

The bundy tube part number CR510415 is supplied in 3.05mt lengths, order lengths as required.

LUBRICATION CHART

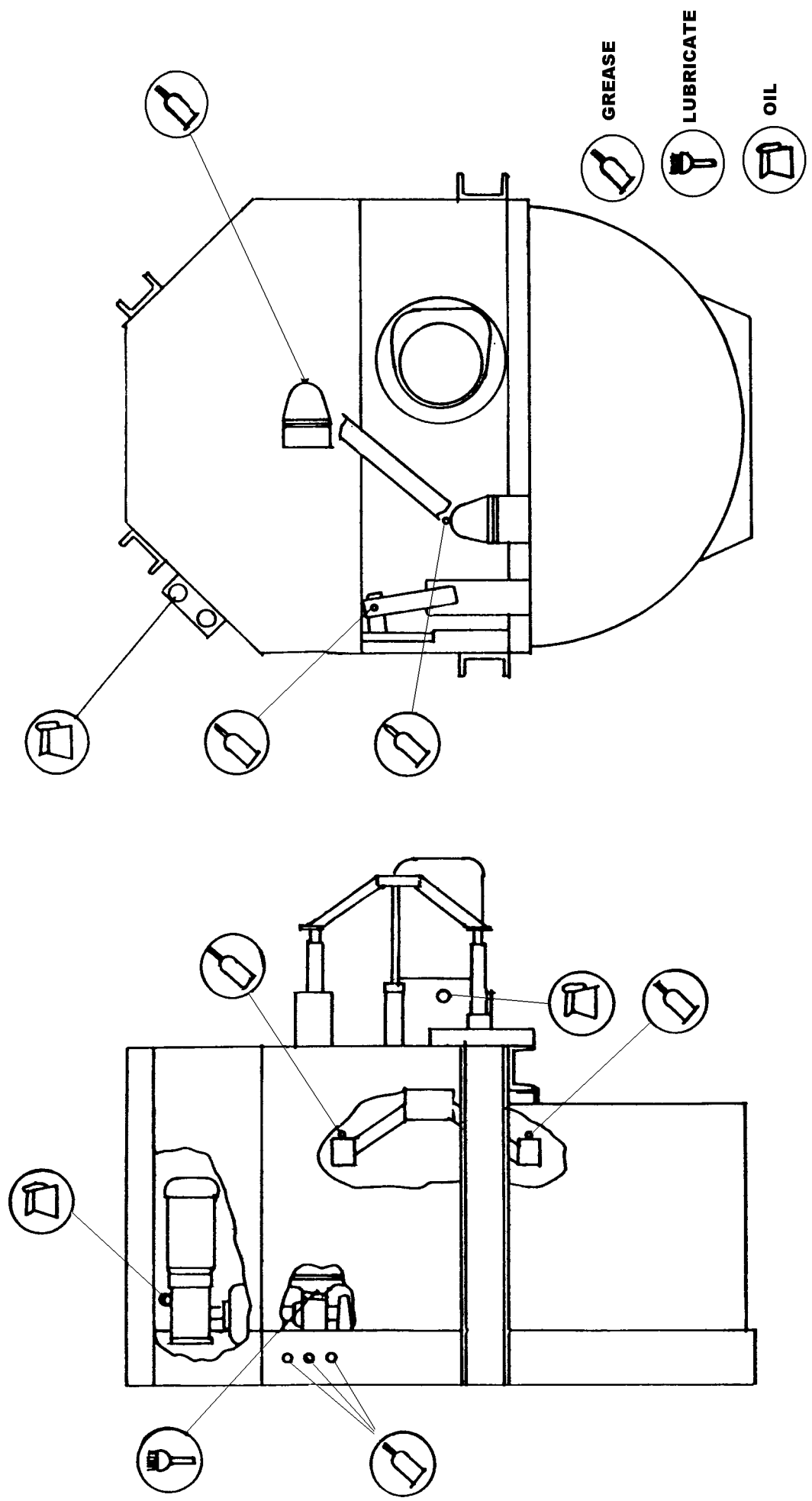

**OPERATING
AND
MAINTENANCE MANUAL**

SECTION 4

MIXER SPARE PARTS

RP550XD GENERAL ARRANGEMENT OF PARTS & TOP AND BOTTOM STRUCTURES

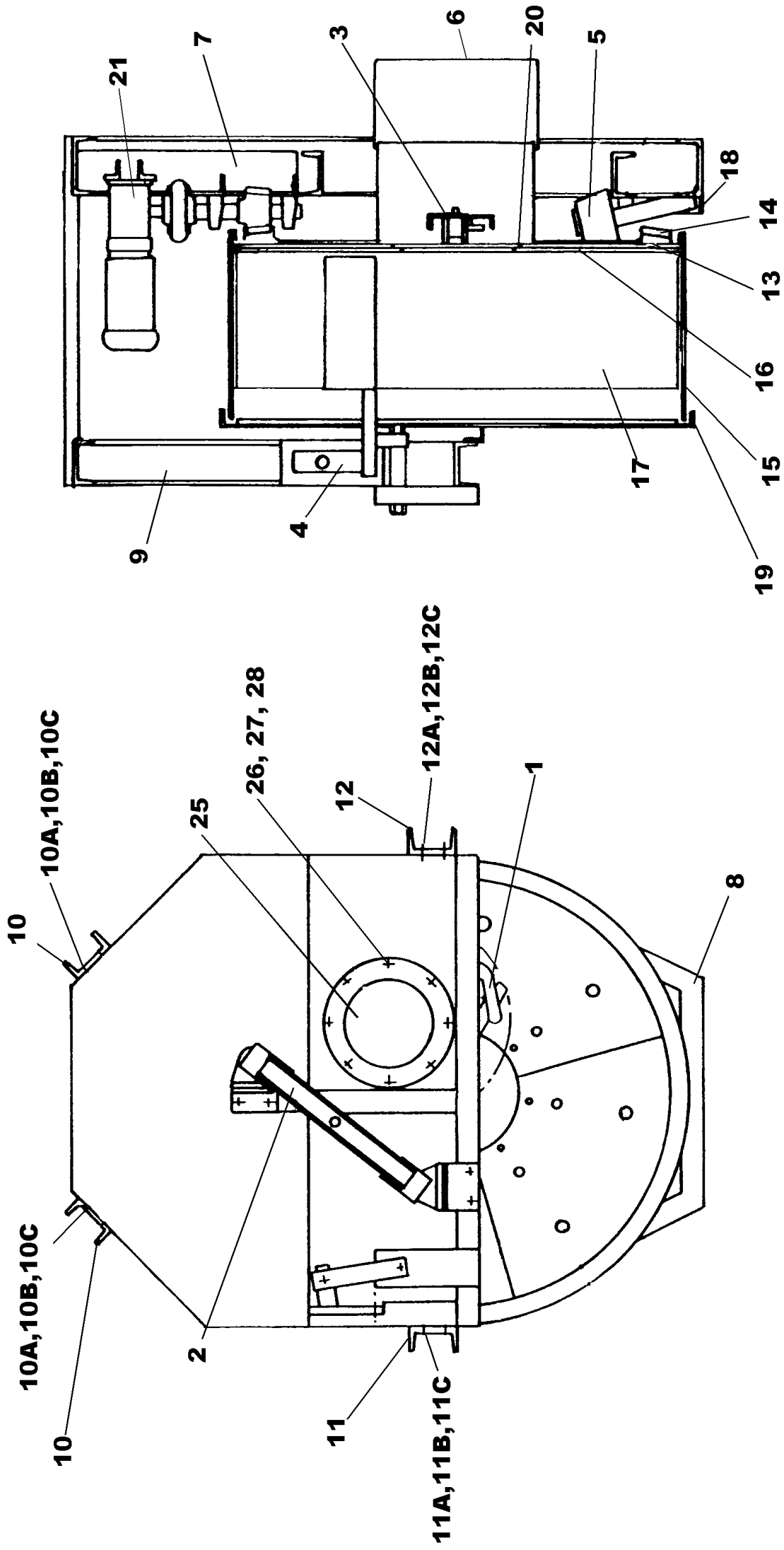

RP550XD GENERAL ARRANGEMENT

1	*	Arrangement of Mixing Star	1
2	*	Discharge of Blade Assembly	1
3	*	Assembly of Discharge Door	1
4	*	Fixed Blade Assembly	1
5	*	Pan Roller Assembly	3
6	*	Door Control Assembly	1
7	*	Pan Drive Assembly	1
8	CR26100327	Lower Chassis Structure	1
9	CR26100322	Top Structure	1
10	CR53100032	Top Structure Support	2
10A	11S06F	Screw Set M16 x 40	16
10B	267S09	Washer Flat	16
10C	61S06	Nut Binx M16	16
11	CR53100031/1	Top Structure Support	1
11A	11S06F	Screw Set M16 x 40	8
11B	267S09	Washer Flat	8
11C	61S06	Nut Binx M16	8
12	CR53100031/2	Top Structure Support	1
12A	11S06F	Screw Set M16 x 40	8
12B	267S09	Washer Flat	8
12C	61S06	Nut Binx M16	8
13	CR26100318	Pan Base, Mild Steel	1
13	CR26100318SS	Pan Base, Stainless Steel	1
14	CR21100364	Pan Rack	1
15	CR54100317	Pan Rim, Mild Steel	1
15	CR54100317SS	Pan Rim, Stainless Steel	1
16	CR53100319	Pan Base Wear Plate, Mild Steel	4
16	CR53100319H	Pan Base Wear Plate, Wear Resistant Steel	4
16	CR53100319SS	Pan Base Wear Plates, Stainless Steel	4
17	CR54100320	Pan Rim Wear Plate, Mild Steel	3
17	CR54100320H	Pan Rim Wear Plate, Wear Resistant Steel	3
17	CR54100320SS	Pan Rim Wear Plate, Stainless Steel	3
18	CR54100347	Pan Guard Bottom Rim	1
19	CR26100332	Pan Rim Brush Track	1
20	CR26100333	Pan Door Seating, Mild Steel	1
20	CR26100333SS	Pan Door Seating, Stainless Steel	1
21	*CR299096	*Pan Drive Motor/Gearbox Flender	1
21A	*CR299096A	*Pan Drive Motor/Gearbox Renold	1
21B	*CR299096B	*Pan Drive Motor/Gearbox Sever UK Spec	1
21C	*CR299096C	*Pan Drive Motor/Gearbox Sever USA/CAN Spec	1
25	*CR299081	*Mixing Star Motor/Gearbox Flender	1
25A	*CR299081A	*Mixing Star Motor/Gearbox Renold	1
25B	*CR299081B	*Mixing Star Motor/Gearbox Sever UK Spec	1
25C	*CR299081C	*Mixing Star Motor/Gearbox Sever USA/Can Spec	1
26	8S06H	Bolt M16 x 60	8
26A	267S09	Washer Flat M16	8
26B	61S06	Nut Binx M16	8

* Quote make and model when ordering parts for motors and gearboxes

* Refer to relevant pages for detailed breakdowns of these assemblies

RP550XD PAN ROLLER ASSEMBLY

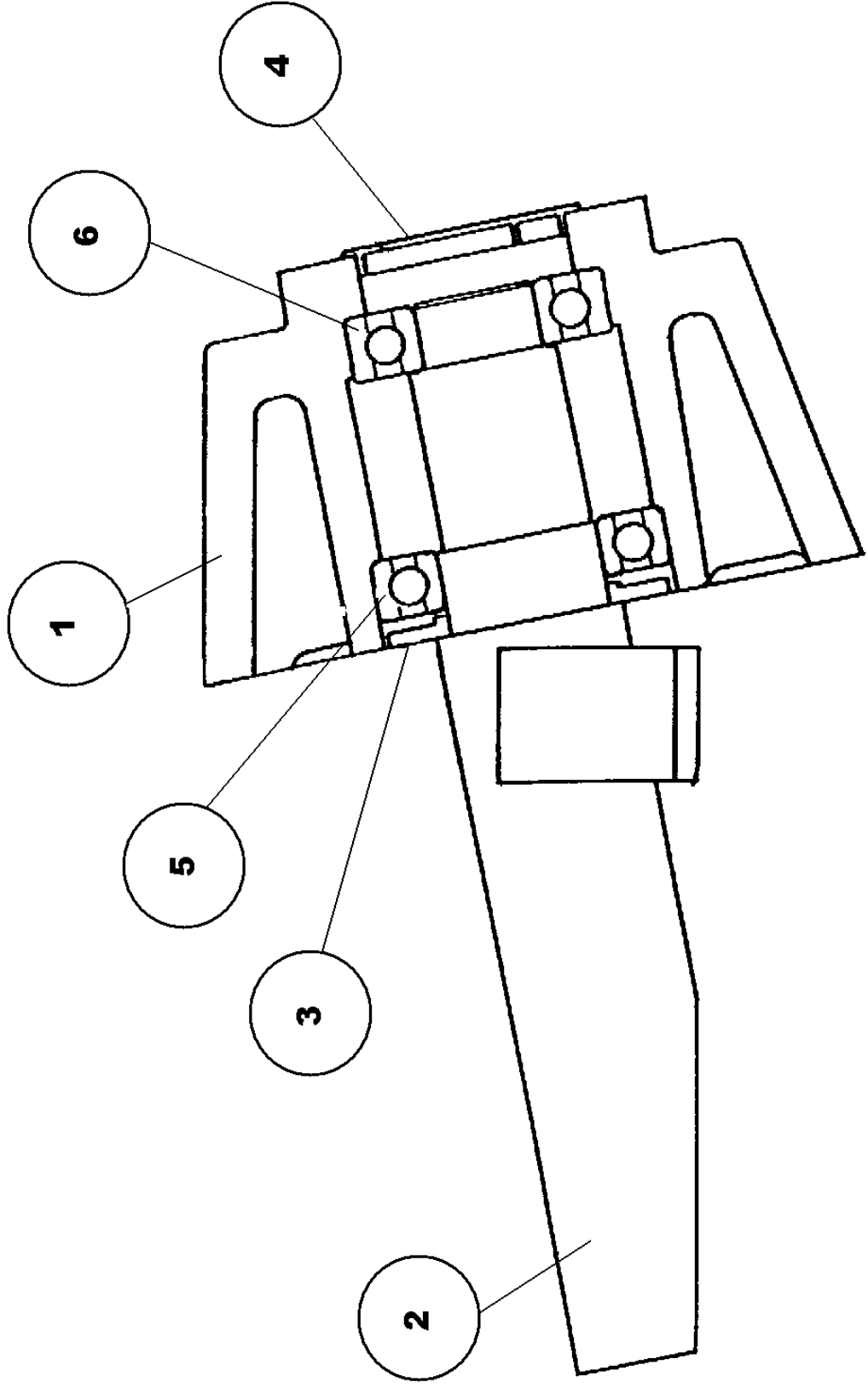

RP550XD PAN ROLLER ASSEMBLY

1	CR21100334	Pan Roller	3
2	CR26100072	Pan Roller Spindle	3
3	CR53100073	Dust Washer	3
4	CR54100074	Dust Cap	3
5	CR150062	Bearing Ball	3
6	CR150126	Bearing Ball	3
7	CR531317	Packing (not illustrated) 1.5 mm Thick	A/R
8	CR531316	Packing (not illustrated) 3mm Thick	A/R
9	CR531315	Packing (not illustrated) 6mm Thick	A/R
10	CR531314	Packing (not illustrated) 10mm Thick	A/R
11	8S06N	Bolt M16 x 90	3
12	8S06F	Bolt M16 x 50	6
13	105S07	Washer Tapered M16	9
14	267S09	Washer Flat M16	9
15	61S06	Nut Binx	9

RP550XD DOOR CONTROL ASSEMBLY

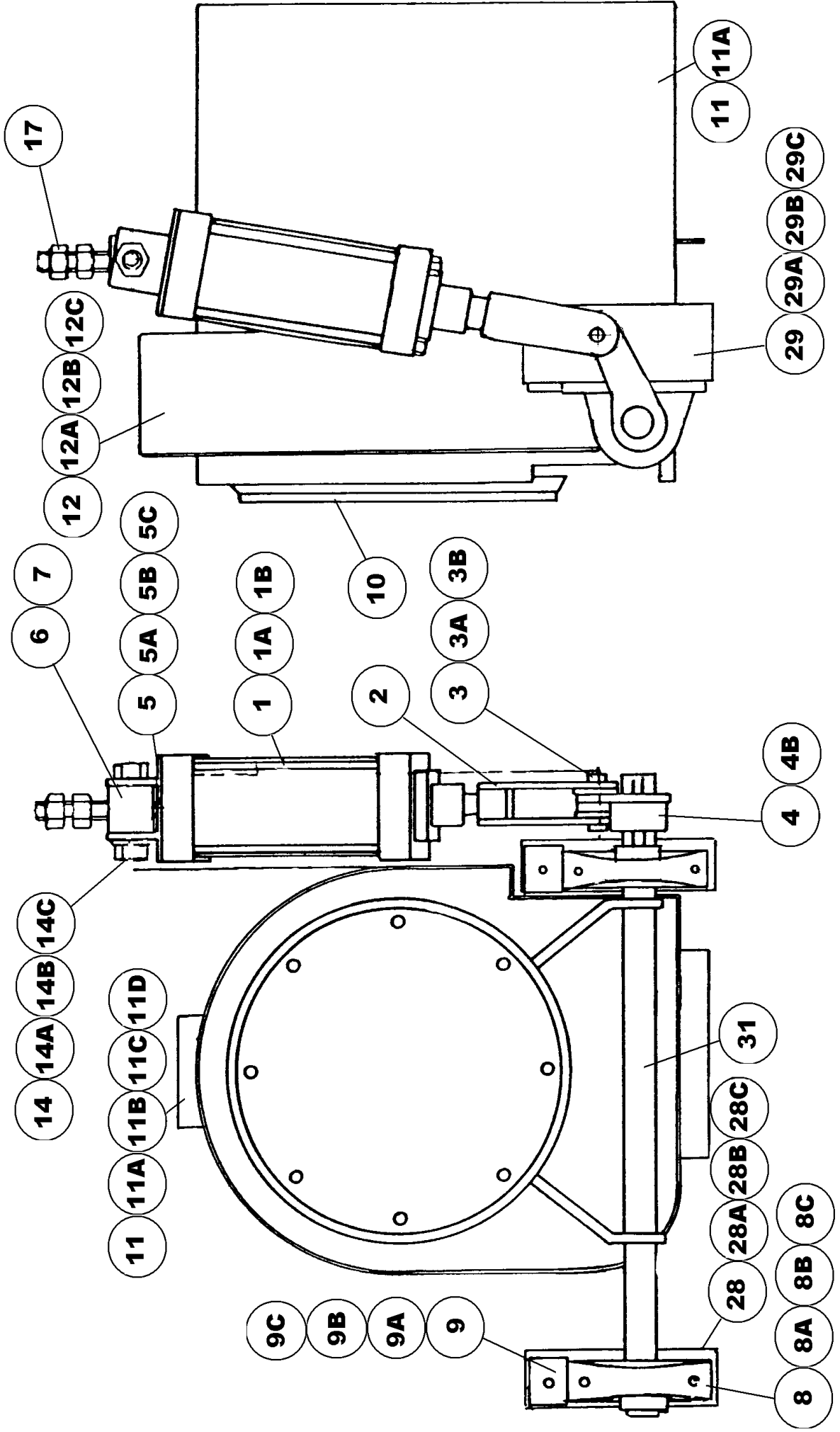

RP550XD DOOR CONTROL ASSEMBLY

1	CR110303	Air Cylinder	1
1A	CR110326	Seal Kit Air Cylinder	1
1B	CR119265	1/2" BSP Male x 12mm Female Push In Elbow	
		Discharge Door Cylinder Both Ends	2
1C	CR119261	Alternative 1/2" BSP Male x 12mm Female Push In Straight Adaptor Dis Door Cylinder Both Ends	2
2	CR26100348	Lever Pivot Holder	1
3	CR52100044	Pin Pivot	1
3A	44S04E	Pin Split	2
3B	10S08	Washer Flat	4
4	CR26100341	Door Arm Lever	1
4A	CR329082	Key Parallel	1
4B	57S05D2	Screw Grub	2
5	CR53100078	Air Cylinder Trunnion Plate	1
5A	7S05	Nut M12	4
5B	17S06	Washer Spring M12	4
5C	267S07	Washer Flat M12	4
6	CR5310075	Air Cylinder Trunnion	1
7	CR1810014	Torsion Bush	1
8	CR159013	Pillow Block Bearing	2
8A	8S05F	Bolt M12	4
8B	61S05	Nut Binx M12	4
8C	267S07	Washer Flat M12	4
9	CR530039	Bearing Stop	2
9A	11S06H	Screw Set M16	2
9B	61S06	Nut Binx M16	2
9C	267S09	Washer Flat M16	2
10		Door Assembly	1
11	CR54100349A	Discharge Chute Upper	1
11A	CR54100349B	Discharge Chute Lower	1
11B	8S04D	Bolt M10	6
11C	7S04	Nut M10	6
11D	17S05	Washer Spring M10	6
12	CR54100350	Door Cylinder Guard	1
12A	11S04C	Screw set M10	2
12B	61S04	Nut Binx M10	2
12C	267S06	Washer Flat M10	2
14	8S08R	Bolt M24 x 120	1
14A	7S08	Nut M24	1
14B	17S11	Washer Spring M24	1
14C	267S12	Washer Flat M24	1
17	7S08	Nut M24	2
28	CR26100328	Door Shaft Bracket	1
28A	8S06E	Screw Set M16	2
28B	61S06	Nut Binx M16	2
28C	267S09	Washer Flat M16	4
29	CR26100331	Door Shaft Bracket (Air Cylinder End)	1
29A	8S06E	Screw Set M16	2
29B	61S06	Nut Binx M16	2
29C	267S09	Washer Flat M16	4
31	CR26100340	Door Arm Assembly	1

RP550XD PAN DRIVE ASSEMBLY

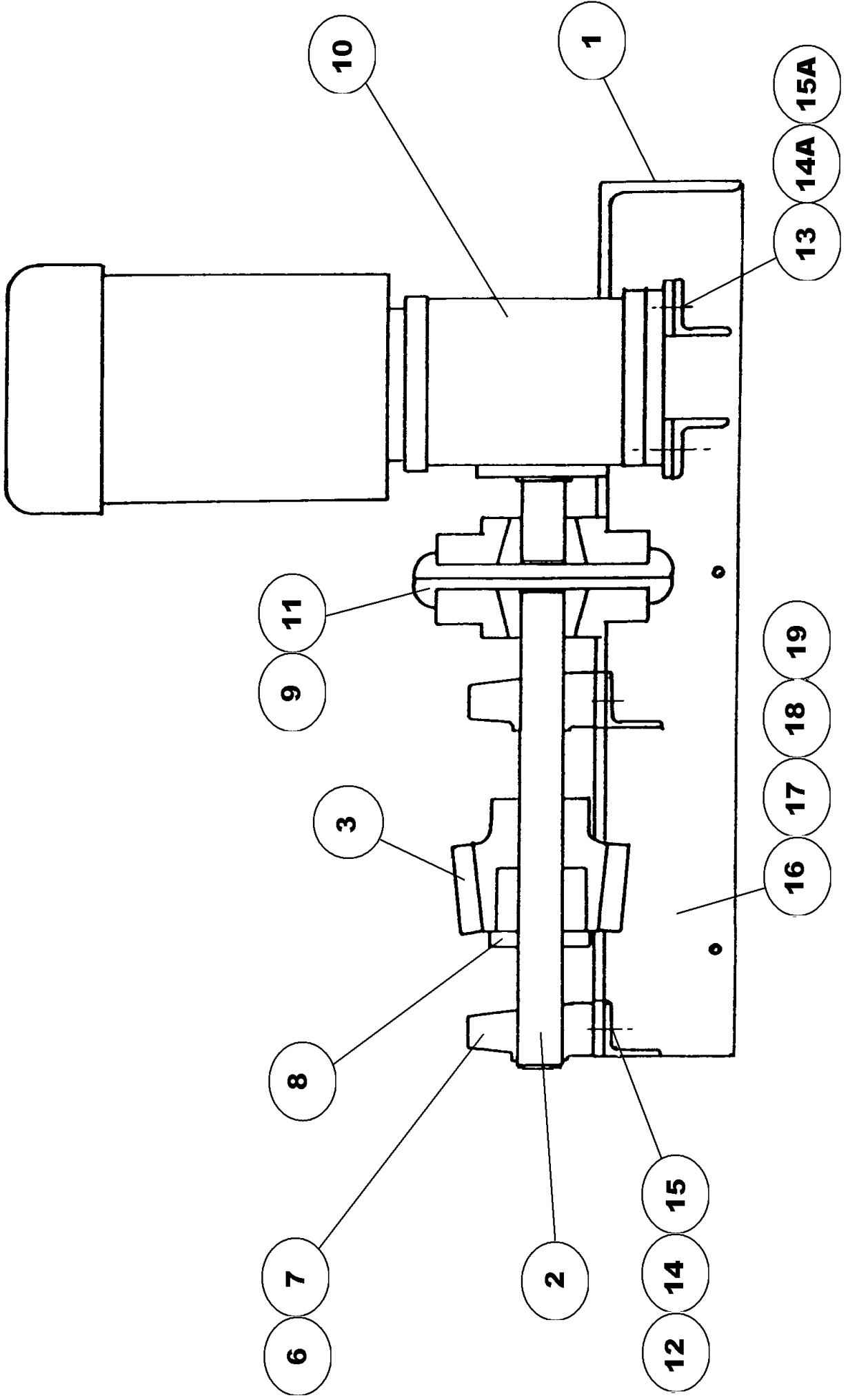

RP550XD PAN DRIVE ASSEMBLY

1	CR26100324	Pan Drive Chassis	1
2	CR52100329	Pan Drive Shaft	1
3	CR46100155	Bevel Pinion	1
6	CR159012	Bearing Plummer Block	2
7	CR530039	Bearing Stop	4
8	CR189004	Bushing, Taper Lock	1
9	CR239014	Flexible Coupling Assembly	1
10	*CR299096	*Pan Drive Gearbox Flender 2.2kw	1
10A	*CR299096A	*Pan Drive Gearbox Renold 2.2kw	1
10B	*CR299096B	*Pan Drive Gearbox Sever UK Spec	1
10C	*CR299096C	*Pan Drive Gearbox Sever US/CAN Spec	1
11	CR329081	Key Parallel	2
12	8S06K	Bolt M16 x 70	8
13	8S05G	Bolt M12 x 55	4
14	61S06	Nut Binx M16	8
14A	61S05	Nut Binx M12	4
15	267S09	Washer Flat M16	8
15A	267S07	Washer Flat M12	4
16	8S06K	Bolt M16 x 70	4
17	267S09	Washer Flat M16	8
18	17S08	Washer Spring M16	4
19	7S06	Nut M16	4
20	CR53100305	Packing (not illustrated)	A/R
21	CR53100306	Packing Single Hole Thick (not illustrated)	A/R

Items 16,17,18,19 Secure pan drive chassis to main chassis unit

*Quote Make & Model of motor/gearbox when ordering spares for this item

RP550XD PAN ASSEMBLY

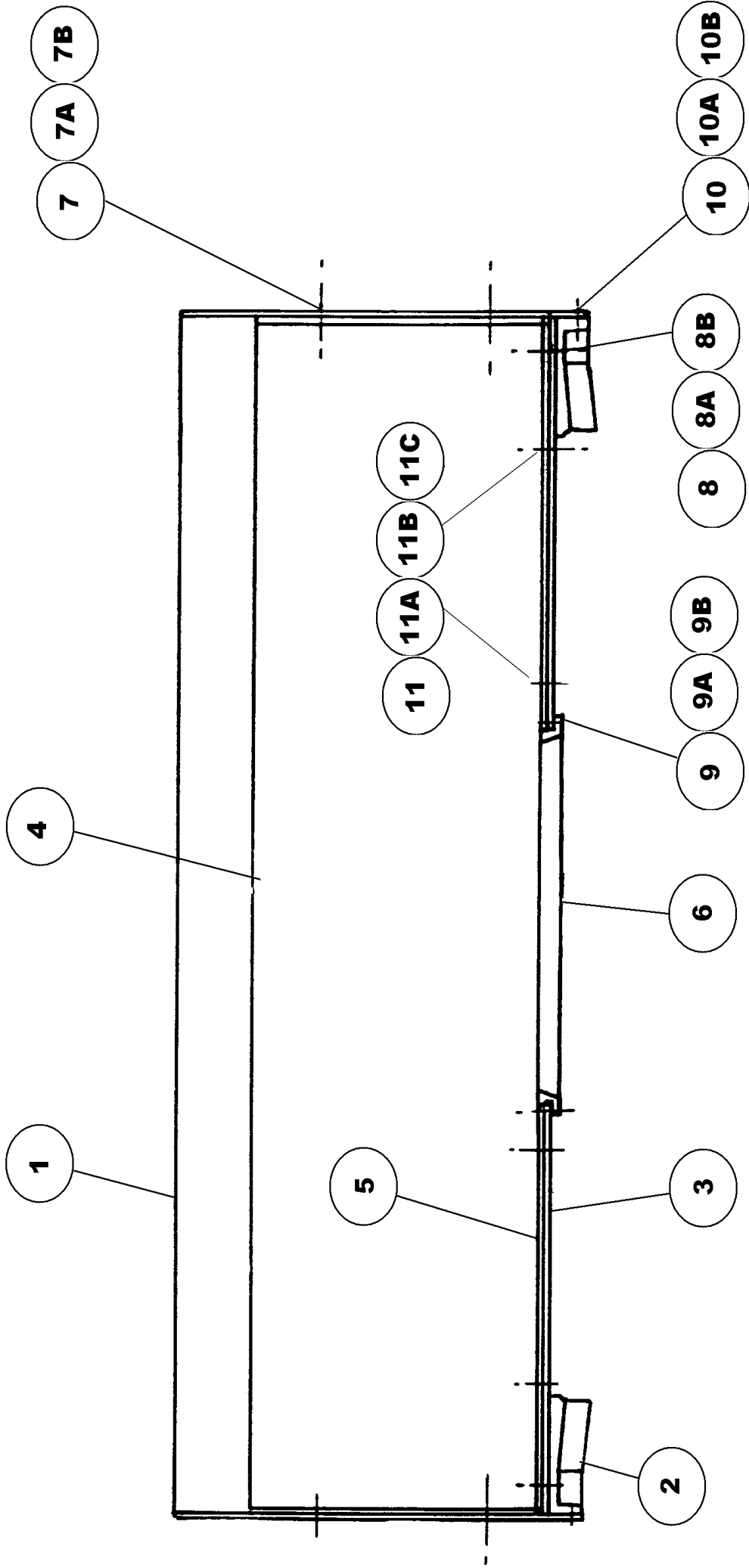

RP550XD PAN ASSEMBLY

1	CR54100317	Pan Rim, Mild Steel	1
1	CR54100317SS	Pan Rim, Stainless Steel	1
2	CR21100364	Pan Rack	1
3	CR26100318	Pan Base, Mild Steel	1
3	CR26100318SS	Pan Base, Stainless Steel	1
4	CR540518	Pan Rim Wear Plates, obsolete use item 4 below	
4	CR54100320	Pan Rim Wear Plates, Mild Steel	3
4	CR54100320H	Pan Rim Wear Plates, Wear Resistant Steel	3
4	CR54100320SS	Pan Rim Wear Plates, Stainless Steel	3
5	CR53100319	Pan Base Wear Plates, Mild Steel	4
5	CR53100319H	Pan Base Wear Plates, Wear Resistant Steel	4
5	CR53100319SS	Pan Base Wear Plates, Stainless Steel	4
6	CR26100333	Door Seat, Mild Steel	1
6	CR26100333SS	Door Seat, Stainless Steel	1
7	52S03E	Countersunk Bolts M8 x 25 Pan Rim Wear Plates	24
7A	61S03	Nut Binx M8	24
7B	267S05	Washer Flat M8	24
8	52S05H	Countersunk Bolts M12 x 40 Pan Rack-Base	16
8A	61S05	Nut Binx M12	16
8B	267S07	Washer Flat M12	16
9	52S03H	Countersunk Bolts M8 x 40 Door Seat-Pan Base	8
9A	61S03	Nut Binx M8	8
9B	267S05	Washer Flat M8	8
10	11S05E	Srew Set M12 x 35 Pan Rim-Base	14
10A	61S05	Nut Binx M12	14
10B	267S07	Washer Flat M12	14
11	52S05H	Countersunk Bolts M12 x 40 Pan Base Wear Plates	16
11A	267S07	Washer Flat M12	16
11B	17S06	Washer Spring M12	16
11C	7S05	Nut M12	16

RP550XD DISCHARGE DOOR ASSEMBLY

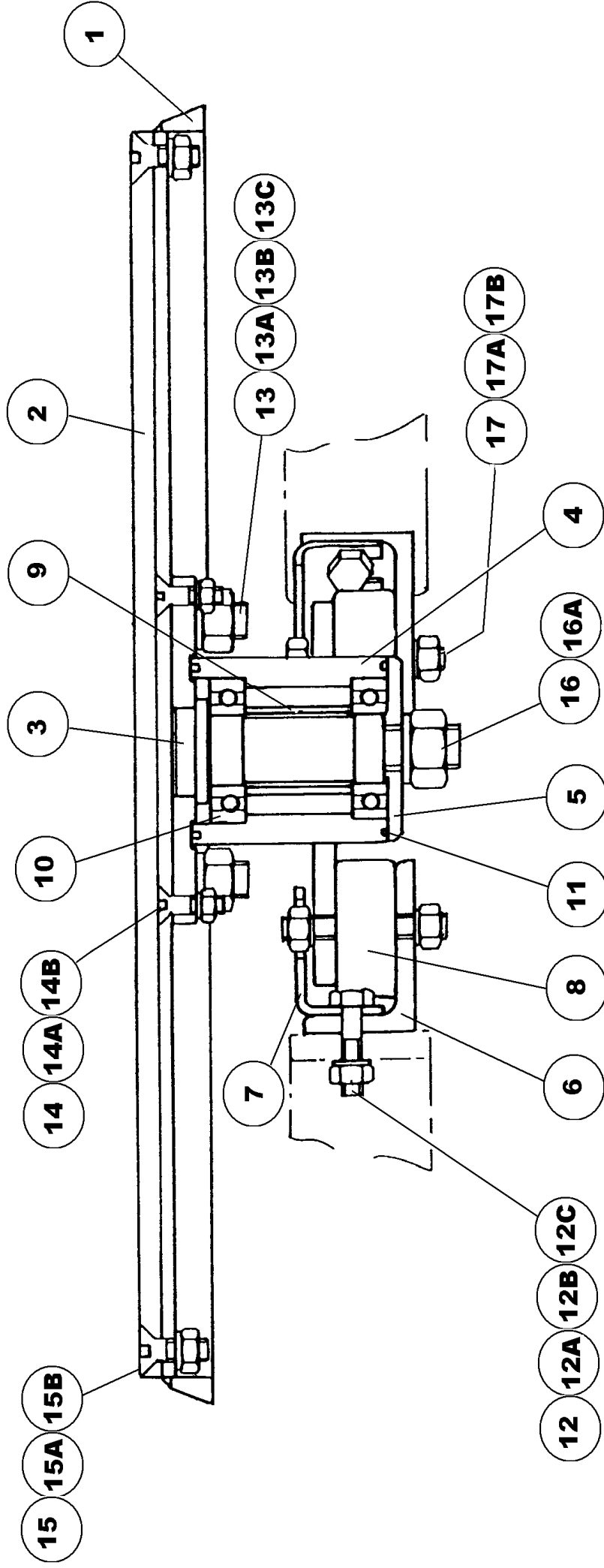

RP550XD ASSEMBLY OF DISCHARGE DOOR

1	CR53100330	Door, Mild Steel	1
1	CR53100330SS	Door, Stainless Steel	1
2	CR53100338	Door Wear Plate, Mild Steel	1
2	CR53100338H	Door Wear Plate, Wear Resistant Steel	1
2	CR53100338SS	Door Wear Plate, Stainless Steel	1
3	CR26100016	Door Pin	1
4	CR26100017	Bearing Housing	1
5	CR49100029	Door Pin Seal Washer	1
6	CR53100033	Support Angle	3
7	CR54100028	Safety Retainer	3
8	CR120003	Anti - Vibration Mounts	3
8A	17S05	Washer Spring M10	6
8B	7S04	Nut M10	6
9	CR63100030	Bearing Spacer	1
10	CR150817	Ball Bearing, obsolete use item 10 below	
10	88S16D	Ball Bearing, Double Sealed	2
11	CR560001	Felt Strip	2
12	8S04D	Bolt M10 x 40	6
12A	267S06	Washer Flat M10	6
12B	17S05	Washer Spring M10	6
12C	7S04	Nut M10	6
13	52S06K	Countersunk Screw M16 x 50	4
13A	267S09	Washer Flat M16	4
13B	17S08	Washer Spring M16	4
13C	7S06	Nut M16	4
14	52S03E	Countersunk Screw M8 x 25	2
14A	17S04	Washer Spring M8	2
14B	7S03	Nut M8	2
15	52S03G	Countersunk Screw M8 x 35	8
15A	17S04	Washer Spring M8	8
15B	7S03	Nut M8	8
16	61S07	Nut Binx M20	1
16A	267S10	Washer Flat M20	1
17	7S04	Nut M10	6
17A	17S05	Washer Spring M10	6
17B	267S06	Washer Flat M10	6

RP550XD DISCHARGE BLADE ASSEMBLY

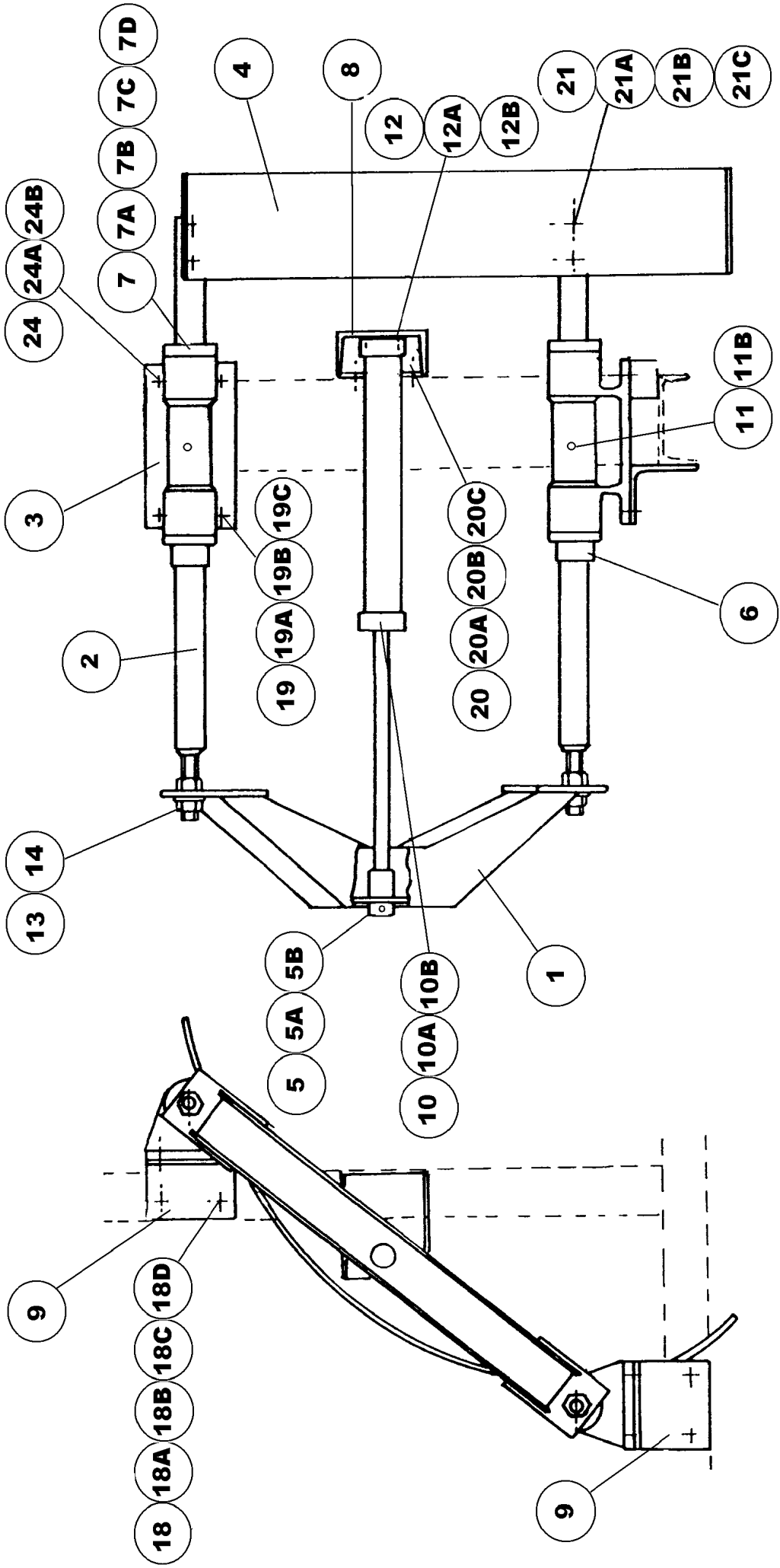

RP550XD DISCHARGE BLADE ASSEMBLY

1	CR26100321	Finger Bridge	1
2	CR52100026	Discharge Blade Finger, Mild Steel	2
2	CR52100026SS	Discharge Blade Finger, Stainless Steel	2
3	CR21100021	Finger Bracket	2
4	CR540721	Discharge Blade, obsolete use item 4 below	
4	CR54100323	Discharge Blade, Mild Steel	1
4	CR54100323H	Discharge Blade, Wear Resistant Steel	1
4	CR54100323SS	Discharge Blade, Stainless Steel	1
5	CR53100335	Piston Rod End	1
5A	54S06M	Pin Roll	1
6	CR53100023	Stop Pipe	2
7	CR53100025	Wiper Seal Housing, Mild Steel, Metric	4
7	CR53100460SS	Wiper Seal Housing, Stainless Steel, Metric	4
7A	CR579030	Seal Wiper, Metric	4
7B	11S02D	Screw Set M6	16
7C	17S03	Washer Spring M6	16
7D	267S04	Washer Flat M6	16
8	CR53100339	Air Cylinder Support (Obsolete from Mc/No 6046)	1
9	CR53100337	Bracket	2
10	CR110304	Air Cylinder Discharge Blade	1
10A	CR110323	Air Cylinder Seal Kit	1
11	131S01	Nipple Grease 1/8" BSP	2
11B	176S01	Cover Nipple Grease	2
12	7S03	Nut M8	4
12A	17S04	Washer Spring M8	4
12B	267S05	Washer Flat M8	4
13	7S08	Nut M24	4
14	267S12	Flat Washer M24	4
18	11S06G	Set Screw M16 x 45	4
18A	267S09	Washer Flat M16	4
18B	17S08	Spring Washer M16	4
18C	7S06	Nut M16	4
18D	105S07	Washer Tapered M16	4
19	11S06G	Set Screw M16 x 45	4
19A	267S09	Washer Flat M16	4
19B	17S08	Spring Washer M16	4
19C	7S06	Nut M16	4
20	11S06G	Set Screw M16 x 45 (Obsolete from Mc/No 6046)	2
20A	267S09	Washer Flat M16 (Obsolete from Mc/No 6046)	2
20B	17S08	Spring Washer M16 (Obsolete from Mc/No 6046)	2
20C	7S06	Nut M16 (Obsolete from Mc/No 6046)	2
21	52S06P	Countersunk Screw M16 x 70	4
21A	267S09	Washer Flat M16	4
21B	17S08	Spring Washer M16	4
21C	7S06	Nut M16	4
24	8S06D	Bolt M16 X 40	4
24A	267S09	Washer Flat M16	4
24B	17S08	Spring Washer M16	4

RP550XD MIXING STAR ASSEMBLY

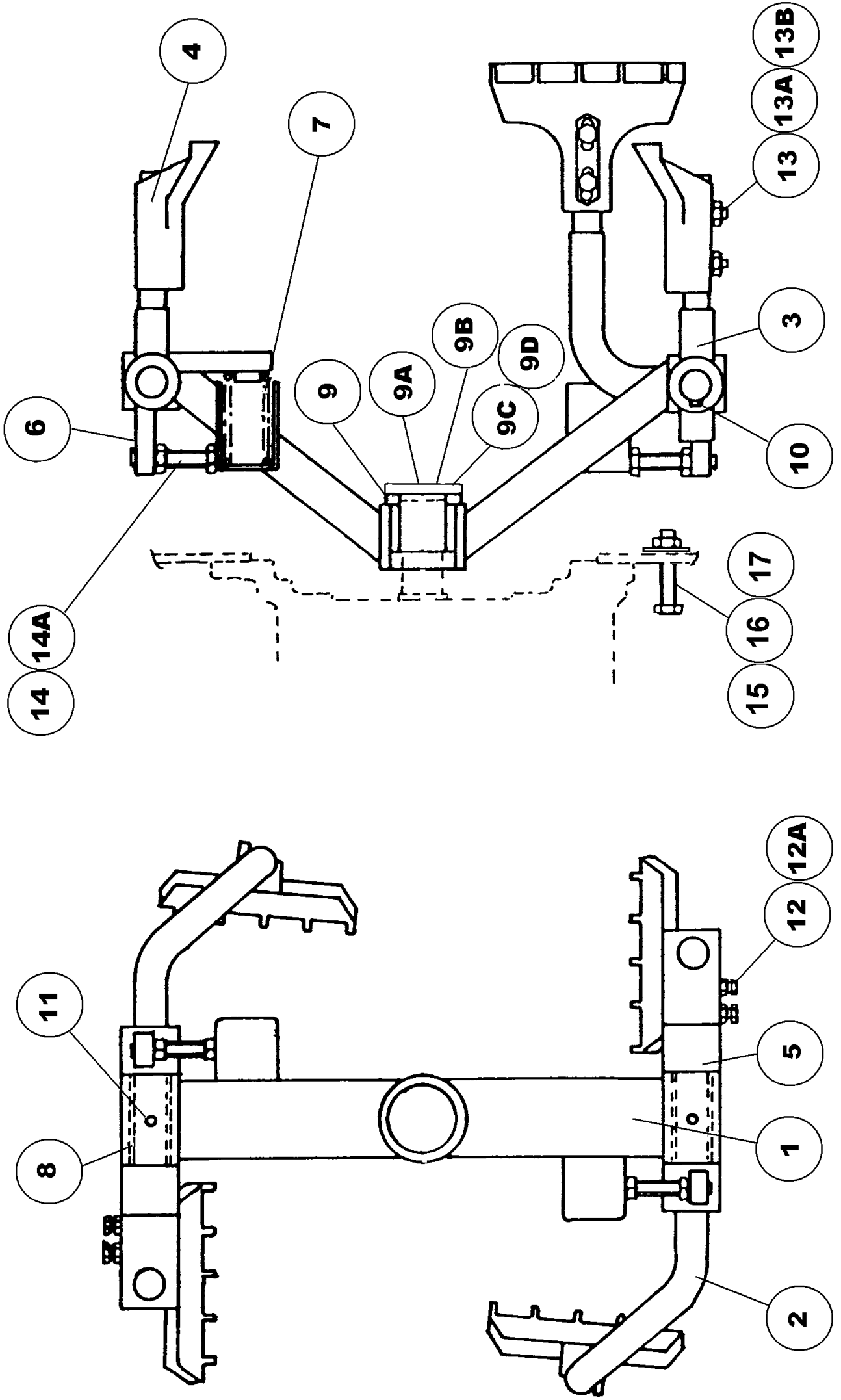

RP550XD ARRANGEMENT OF MIXING STAR

1	CR26100325	Mixing star, Mild Steel	1
1	CR26100325SS	Mixing Star, Stainless Steel	1
2	CR26100326	Star Blade Finger (Long, includes Item 6 below)	2
2	CR26100326SS	Star Blade Finger Long, Stainless Steel	2
3	CR26100005	Star Blade Finger (Short) Mild Steel	2
3	CR26100005SS	Star Blade Finger (Short) Stainless Steel	2
4	CR210035	Star Blade (Cast, obsolete use item 4 below)	
4	CR21100015	Star Blade, cast	4
4A	CR210035P	Star Blade (Polyurethane Alternative)	4
5	CR63100376	Spacer	2
6	CR26100006	Lever for Compression Spring (Part of Item 2)	2
7	CR330070	Spring Compression	2
8	CR189006	Bush Oilite	4
9	CR189005	Bush SH Taper Lock	1
9A	CR539189	Cap End	1
9B	CR320060	Key Star, Gib Head	1
9C	11S07F	Screw Set M20 x 40	1
9D	17S09	Washer Spring M20	1
10	CR329068	Key Parallel, Star Blade Finger	2
11	CR280008	Grease Nipple	2
12	68S06F	Cap Screw M12 x 35	4
12A	7S05	Nut M12	4
13	8S06K	Bolt M16 x 70	8
13A	267S09	Washer Flat M16	8
13B	61S06	Nut Binx M16	8
14	11S07T	Screw Set M20 x 100	2
14A	7S07	Nut M20	2
15	8S06H	Bolt M16 x 60 Star Gearbox to Frame	8
16	267S09	Washer Flat M16	8
17	61S06	Nut Binx M16	8

RP550XD FIXED BLADE ASSEMBLY

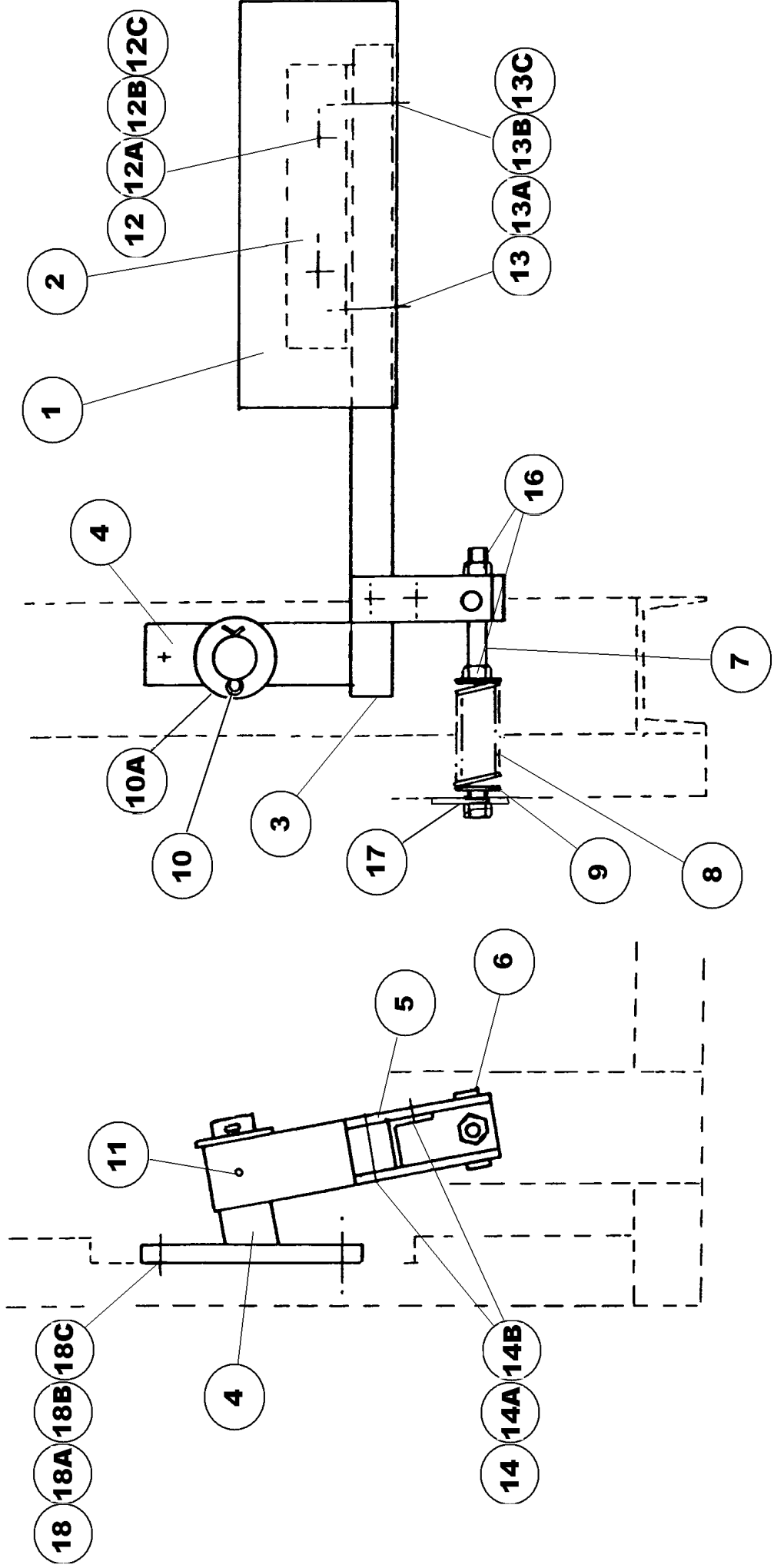

RP550XD FIXED BLADE ASSEMBLY

1	CR530034	Fixed Blade, obsolete use item 1 below	
1	CR53100039	Fixed Blade, Mild Steel	1
1	CR53100039H	Fixed Blade, Wear Resistant Steel	1
1	CR53100039SS	Fixed Blade, Stainless Steel	1
2	CR53100040	Fixed Blade Angle, Mild Steel	1
2	CR53100040SS	Fixed Blade Angle, Stainless Steel	1
3	CR26100035	Fixed Blade Finger, Mild Steel	1
3	CR26100035SS	Fixed Blade Finger, Stainless Steel	1
4	CR26100038	Finger Pivot, Mild Steel	1
4	CR26100038SS	Finger Pivot, Stainless Steel	1
5	CR53100037	Trunnion Plate	1
6	CR53100036	Trunnion Adjusting Rod	1
7	CR53100041	Adjusting Rod	1
8	CR330066	Spring	1
9	CR49100059	Adjusting Rod Washer	2
10	44S06L	Split Pin	1
10A	CR49100801	Washer Machined	1
11	131S01	Grease Nipple 1/8" BSP	1
11A	176S01	Cover Nipple Grease	1
12	52S05H	Countersunk Screw M12 x 40	2
12A	267S07	Washer Flat M12	2
12B	17S06	Washer Spring M12	2
12C	7S05	Nut M12	2
13	8S05M	Bolt M12 x 80	2
13A	267S07	Washer Flat M12	2
13B	17S06	Washer Spring M12	2
13C	7S05	Nut M12	2
14	8S05M	Bolt M12 x 80	2
14A	267S07	Washer Flat M12	2
14B	17S06	Washer Spring M12	2
16	7S07	Nut M20	2
17	272127006	Washer Flat Special	1
18	8S06P	Bolt M16 x 100	2
18A	CR530647	Washer Flat/Square M16	2
18B	61S06	Nut Binx M16	2
18C	CR530647	Washer Square	2

RP550XD PAN GUARDS

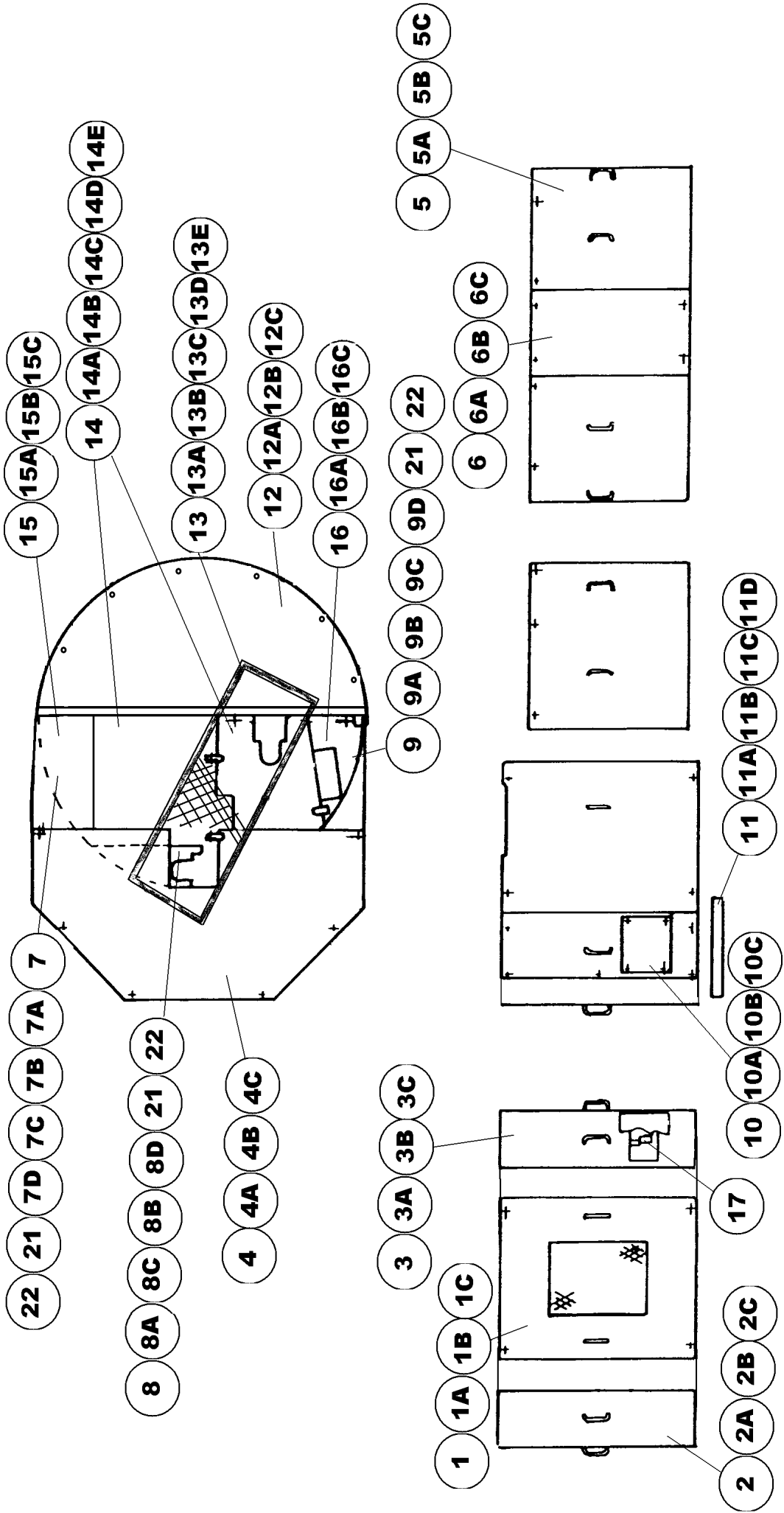

RP550XD PAN GUARDS

11	CR54100363	Bevel Pinion & Drive Guard	1
11A	11S03C	Screw Set M8	4
11B	17S04	Washer Spring M8	4
11C	267S05	Washer Flat M8	4
11D	7S03	Nut M8	4
12	CR54100775	Cover, Plain-Refer to Section 8.2 for details of details of Special Pan Covers	1
12A	11S03A	Screw Set M8	8
12B	17S04	Washer Spring M8	8
12C	267S05	Washer Flat M8	8
13	CR539168	Guard Discharge Blade Fingers	1
13A	555287900	Spacer Guard Support	3
13B	8S05U	Bolt M12 x	3
13C	7S05	Nut M12	3
13D	17S06	Washer Spring M12	3
13E	267S07	Washer Flat M12	3
14	CR54100786	Cover Top Flender Star Drive	1
14A	N.P.N.	Cover Top Sever Star Drive	1
14B	CR54100785	Cover Top Infill	1
14C	11S02A	Screw Set M6	8
14D	17S03	Washer Spring M6	8
14E	267S04	Washer Flat M6	8
15	CR54100787	Cover Top LH	1
15A	11S02A	Screw Set M6	4
15B	17S03	Washer Spring M6	4
15C	267S04	Washer Flat M6	4
16	CR54100784	Cover Top RH	1
16A	11S02A	Screw Set M6	4
16B	17S03	Washer Spring M6	4
16C	267S04	Washer Flat M6	4
17	CR119190	Box Control	1
21	V2003587	Seal Rubber (Order by Metre)	A/R
22	V2003225	Seal Rubber (Order by Metre)	A/R

RP550XD PAN SEALING STRIP

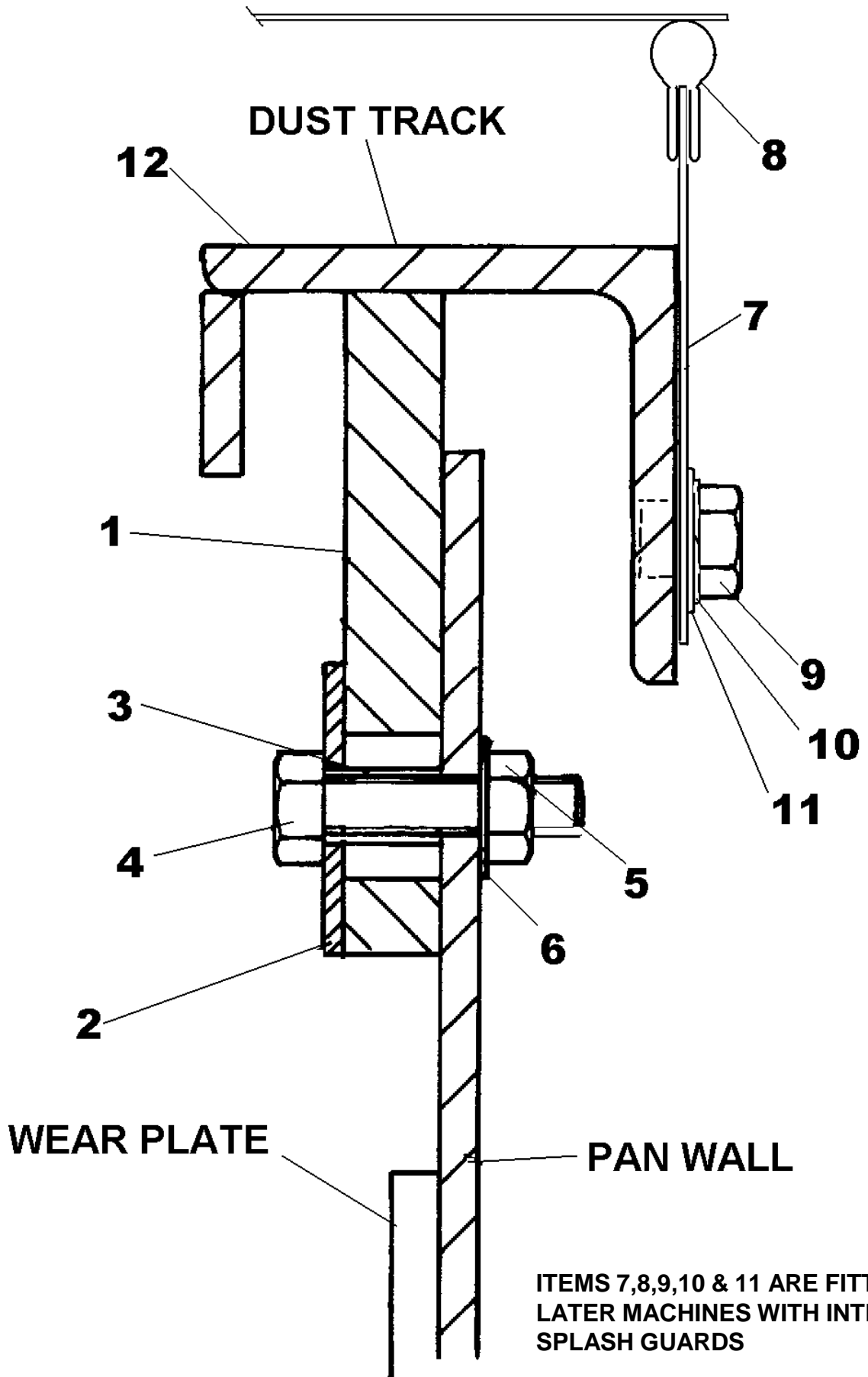

RP550XD PAN SEALING STRIP

1	CR479005	Pan Sealing Rubber	4
2	CR539124	Retaining Plate	4
3	CR529035	Spacer	16
4	8S03C	Screw Set M8 x 35	16
5	61S03	Nut Binx M8	16
6	267S05	Washer Flat M8	16
7	N.P.N.	Guard Wrap Round	3
8	V2003587	Seal Rubber	3MT
9	11S03A	Screw M8	12
10	17S04	Washer Spring M8	12
11	267S05	Washer Flat M8	12
12	CR26100332	Pan Dust Track	1

The following track retaining brackets are not illustrated

13	8S05D	Bolt M12 Track to top Structure Rear	2
13A	61S05	Nut Binx M12	2
13B	267S07	Washer Flat M12	4
14	11S05D	Screw Set M12 Track to rear Bracket	2
14A	61S05	Nut Binx M12	2
14B	267S07	Washer Flat M12	2
15	CR26100779	Bracket Track to Front Bracket	1
15A	11S03C	Screw Set M8	1
15B	17S04	Washer Set M8	1
15C	267S05	Washer Flat M8	8
16	CR26100778	Bracket, Track Bracket to Top Structure Front	1
16A	11S04B	Screw Set M10	1
16B	17S05	Washer Spring M10	1
16C	267S06	Washer Flat, M10	1

RP550XD DECALS AND LOGOS

1 CROKER CUMFLOW RP550XD

WINGET WINGET LIMITED 125, 127 & 129, The Bridge Lane, Bilsborrow Lancashire, Lancashire, England, UK	
Model	
Serial No.	
Engine No.	
Capacity	Mass (kg)
SRO No.	Power (kW)
Year Of Manuf.	Eng. (rpm) Drum (rpm)

W550037

A CROKER GROUP COMPANY

2

4

WINGET

5

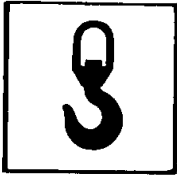

6



7



8

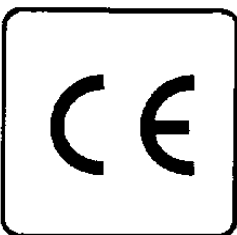

9

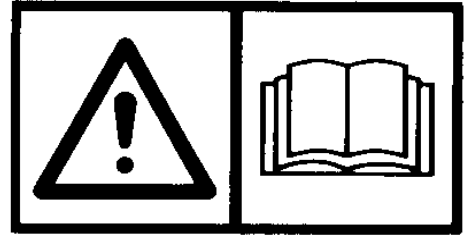

10

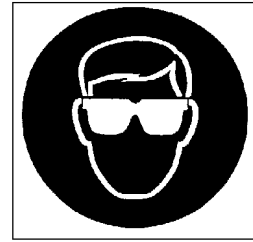

11

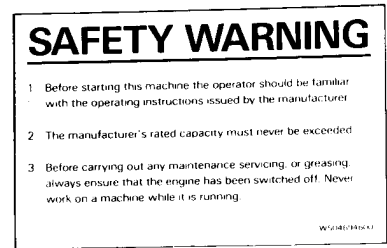

12

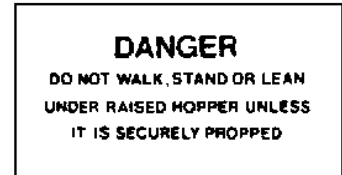

13

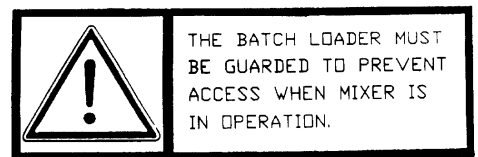

14

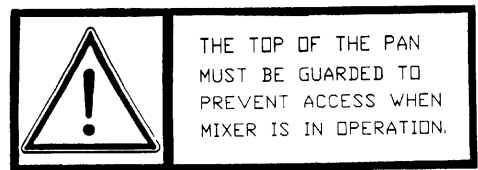

RP550XD DECALS AND LOGOS

1	CR85100766	Decal RP550XD	3
2	V2003037	Plate Serial Number	1
3	101S05D	Rivet Pop	4
4	V2003039	Decal WINGET Medium	3
5	V2003665	Decal Sling Point	4
6	V2003598	Decal British Made	3
7	V2004307	Decal Electrical Hazard	5
8	V2004223	Decal CE Mark	1
9	V2004229	Decal Operators Handbook	3
10	V2004744	Decal Eye Protection	3
11	504694600	Decal Safety	3
12	513331600	Decal Danger	8
13	CR85100771	Decal Batch Loader Guarding	2
14	CR85100772	Decal Pan Guarding	2

**OPERATING
AND
MAINTENANCE MANUAL**

SECTION 5

**OPTIONAL ANCILLARY EQUIPMENT
SPARE PARTS**

RP550XD WINCH UNIT

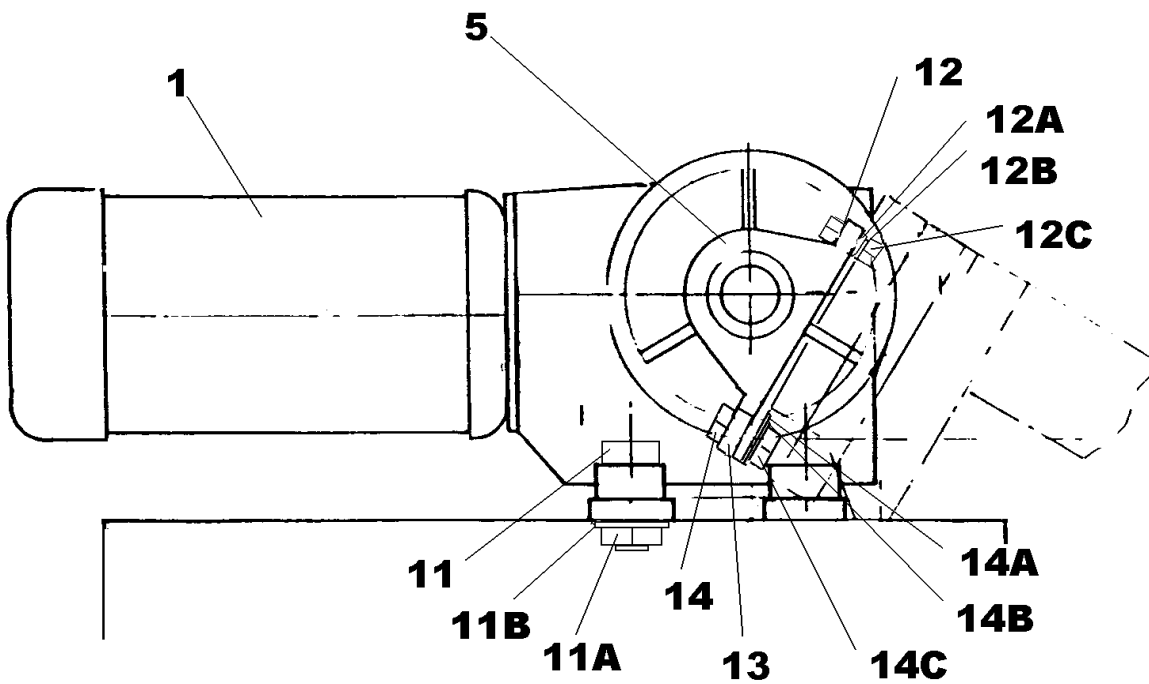
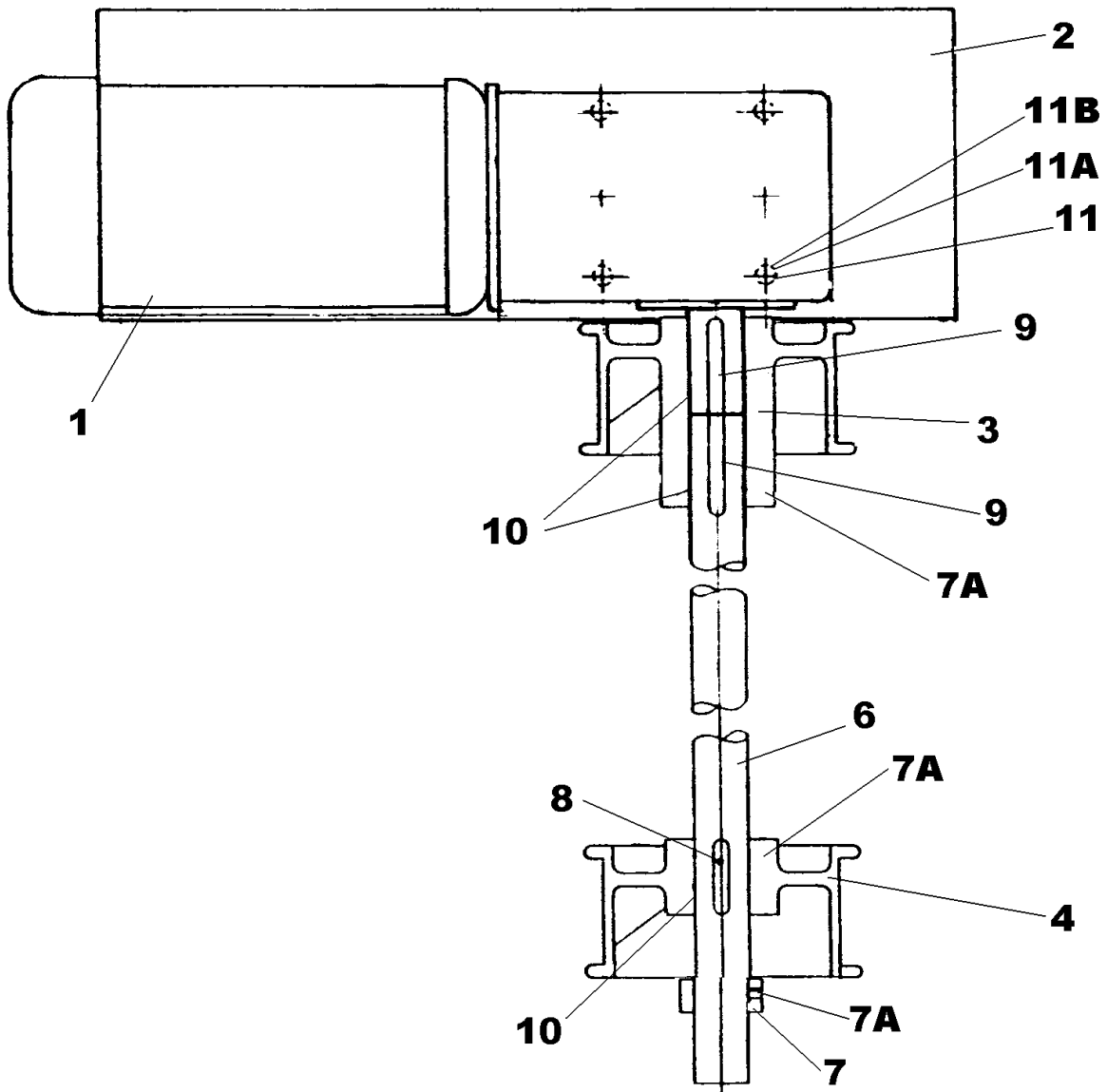

RP550XD WINCH ASSEMBLY

1	CR299114	Combined Motor Brake & Gear Unit (Flender)	1
2	CR269161	Motor Bedplate	1
3	CR21100101	Rope Drum Motor Side	1
4	CR21100102	Rope Drum	1
5	CR151096	Rope Drum Shaft Bearing	1
6	CR52100119	Rope Drum Shaft	1
7	CR630244	Locking Collar	1
7A	57S07F1	Screw Grub M12 X 16	3
8	CR329072	Key Parallel 18 X 11 X 140	1
9	CR329092	Key Parallel 18 X 11 X 100	2
10	CR569028	Loctite Fluid	1
11	8S07N	Hex Head Bolt M20 X 90	4
11A	61S07	Nut Binx M20	4
11B	267S10	Washer Flat M20	4
12	8S06H	Bolt M16 x 60	2
12A	267S09	Washer Flat M16	2
12B	17S08	Washer Spring M16	2
12C	7S06	Nut M16	2
13	CR530039	Bearing Stop	1
14	11S06H	Screw Set M16 x 50	1
14A	267S09	Washer Flat M16	1
14B	17S08	Washer Spring M16	1
14C	7S06	Nut M16	1

RP550XD LOADER RUNWAY ASSEMBLY

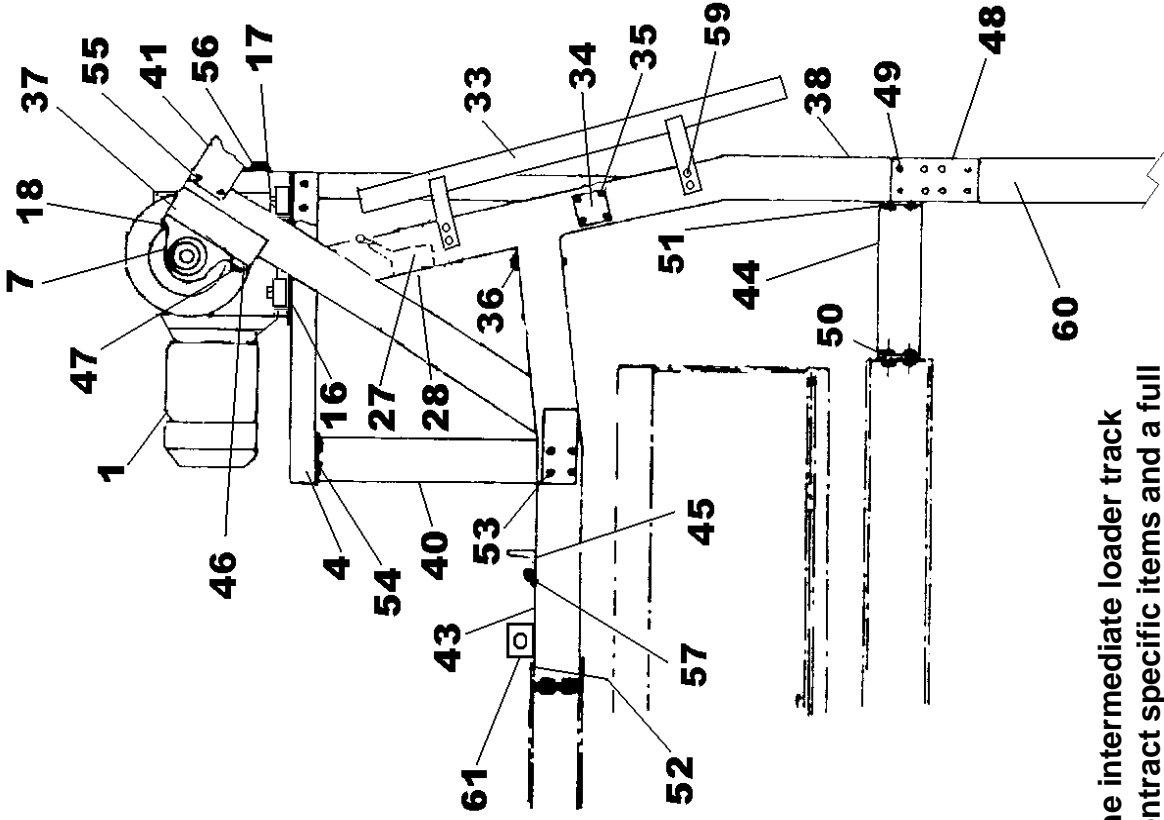
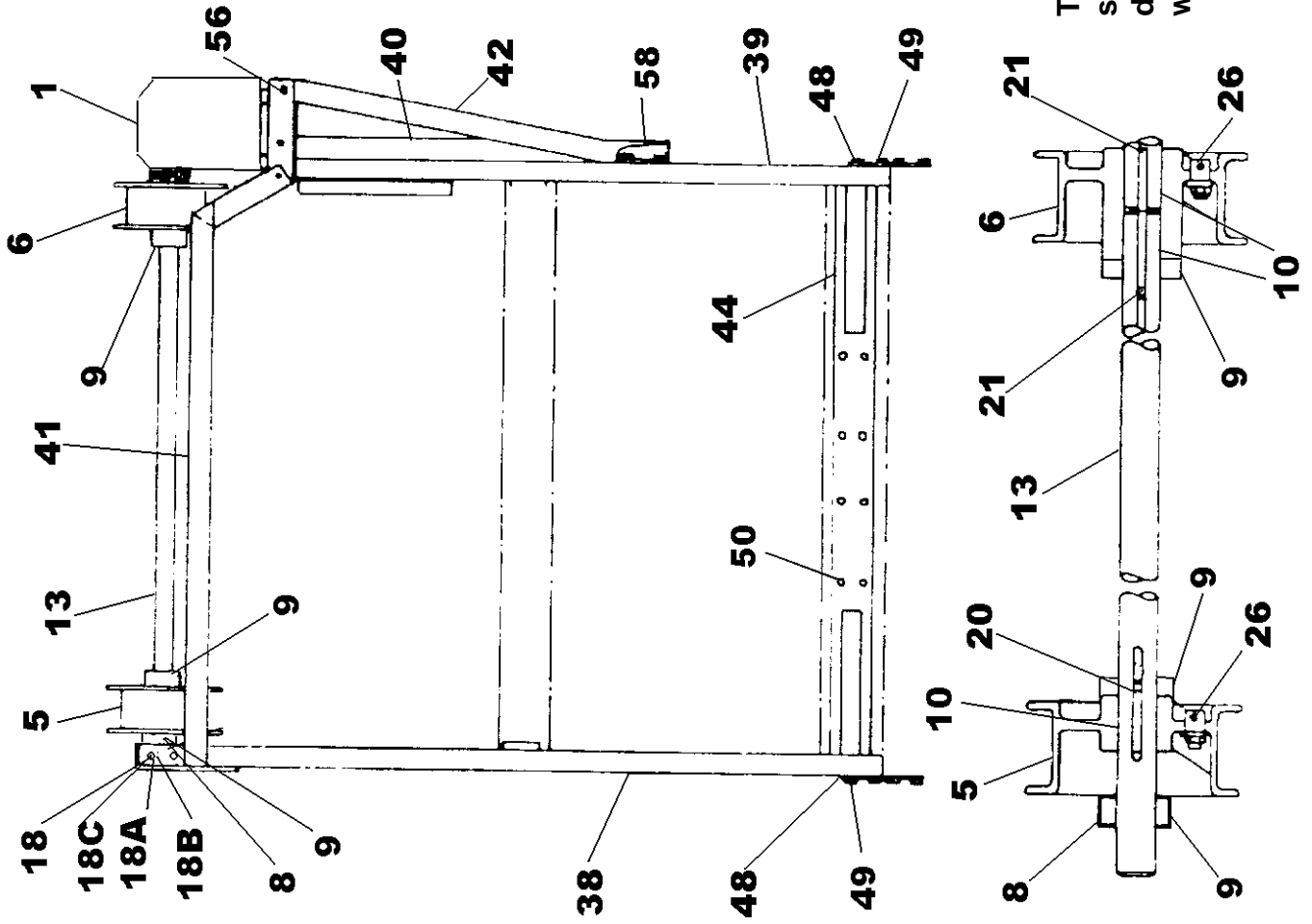

The length of the intermediate loader track sections are contract specific items and a full description including the length must be given when ordering replacements

RP550XD LOADER RUNWAY

1	CR299114	Combined Motor Brake & Gear Unit	1
4	CR269161	Motor Bedplate	1
5	CR21100101	Rope Drum	1
6	CR21100102	Rope Drum Motor Side	1
7	CR151096	Rope Drum Shaft Support Bearing	1
8	CR630244	Shaft Locking Collar	1
9	57S07F1	Screw Grub M12 x 16	3
10	CR569028	Loctite Fluid	1
13	CR52100119	Rope Drum Shaft	1
16	61S07	Nut Binx M20	4
17	8S07N	Bolt M20 x 90	4
17A	267S10	Washer Flat M20	4
18	8S06H	Bolt M16 x 60	2
18A	267S09	Washer Flat M16	2
18B	17S08	Washer Spring M16	2
18C	7S06	Nut M16	2
20	CR329072	Key Parallel 18 X 11 X 40	1
21	CR329092	Key Parallel 18 X 11 X 100	2
26	CR530587	Rope Anchor Bolts (Special)	2
27	CR229083	Limit Switch	1
27A	8S01C	Limit Switch Retaining Bolts M5	4
27B	17S02	Washer Spring M5	4
27C	267S03	Washer Spring M5	4
27D	7S01	Nut M5	4
28	CR54100788	Bracket Limit Switch	1
28A	11S03C	Screw Set M8 x 25	2
28B	105S02	Washer Tapered M8	2
28C	267S05	Washer Flat M8	2
28D	59S12	Nut Nyloc M8	2
29	CR229178	End Stop Limit Switch (Not Illustrated)	2
33	CR260336L	Guide Rail LeftHand	1
33A	CR260336R	Guide Rail Right Hand	1
34	CR620006	Caution Plate	2
35	11S02B	Screw Set M6 X 20	8
35A	267S04	Washer Flat M6	16
35B	17S03	Washer Spring M6	8
35C	7S02	Nut M6	8
36	CR530599	Hopper Safety Bolt & Chain	2
37	CR26100115	Bearing Support Angle	1
38	CR53100125	Runway, Opposite Winch Unit Side	1
39	CR53100124	Runway, Winch Unit Side	1
40	CR530592	Winch Unit Support Channel	1
41	CR261099	Runway Cross Tie	1
42	CR260358	Winch Unit Support Angle	1
43	CR530594	LH & RH Runway Tie Channels	2
44	CR53100904	Runway, Bottom Support Assembly	1
45	CR53100127	Loader Tie	1
46	CR530039	Bearing Stop	1
47	11S06H	Screw Set M16 x 50 Bearing Stop	1

RP550XD LOADER RUNWAY

47A	267S09	Washer Flat M16	1
47B	17S08	Washer Spring M16	1
47C	7S06	Nut M16	1
48	CR530597	Runway GussetPlate	2
49	52S05G	Gusset Plate C/Sunk Screw Set M12 x 35	16
49A	267S07	Washer Flat M12	16
49B	17S06	Washer Spring M12	16
49C	7S05	Nut M12	16
50	11S06T	Bottom Support-Mixer Screw Set M16 x	8
50A	267S09	Washer Flat M16	16
50B	17S08	Washer Spring M16	8
50C	7S06	Nut M16	8
51	52S05G	Bottom Support-Runway C/Sunk Sets M12 x 35	4
51A	267S07	Washer Flat M12	4
51B	17S06	Washer Spring M12	4
51C	7S05	Nut M12	4
52	11S06H	Runway Tie Channel Screw Set M16 x 50	8
52A	267S09	Washer Flat M16	8
52B	17S08	Washer Spring M16	8
52C	7S06	Nut M16	8
53	11S06F	Runway Tie Screw Set M16 x 40	8
53A	267S09	Washer Flat M16	8
53B	17S08	Washer Spring M16	8
53C	7S06	Nut M16	8
54	11S06G	Winch Support Channel Screw Set M16 x 45	4
54A	267S09	Washer Flat M16	4
54B	17S08	Washer Spring M16	4
54C	7S06	Nut M16	4
55	11S06F	Runway Cross Tie Screw Set M16 x 40	4
55A	267S09	Washer Flat M16	4
55B	17S08	Washer Spring M16	4
55C	7S06	Nut M16	4
56	11S06H	Winch Support Angle Screw Set M16 x 50	4
56A	267S09	Washer Flat M16	4
56B	17S08	Washer Spring M16	4
56C	7S06	Nut M16	4
57	11S06H	Loader Tie Angle Screw Set M16 x 50	2
57A	267S09	Washer Flat M16	2
57B	17S08	Washer Spring M16	2
57C	7S06	Nut M16	2
58	52S05J	Winch Support Angle C/Sunk Set M12 x 45	2
58A	267S07	Washer Flat M12	2
58B	17S06	Washer Spring M12	2
58C	7S05	Nut M12	2
59	52S05G	Guide Rail C/Sunk Screw Sets M12 x 35	8
59A	267S07	Washer Flat M12	8
59B	17S06	Washer Spring M12	8
59C	7S05	Nut M12	8
60	N.P.N	LH & RH Intermediate Runway Sections Quote length and section dimensions	2
61	CR530630	Lifting Eyes (Weldable)	2

RP550XD ARRANGEMENT OF WEIGHER & LOADING HOPPER

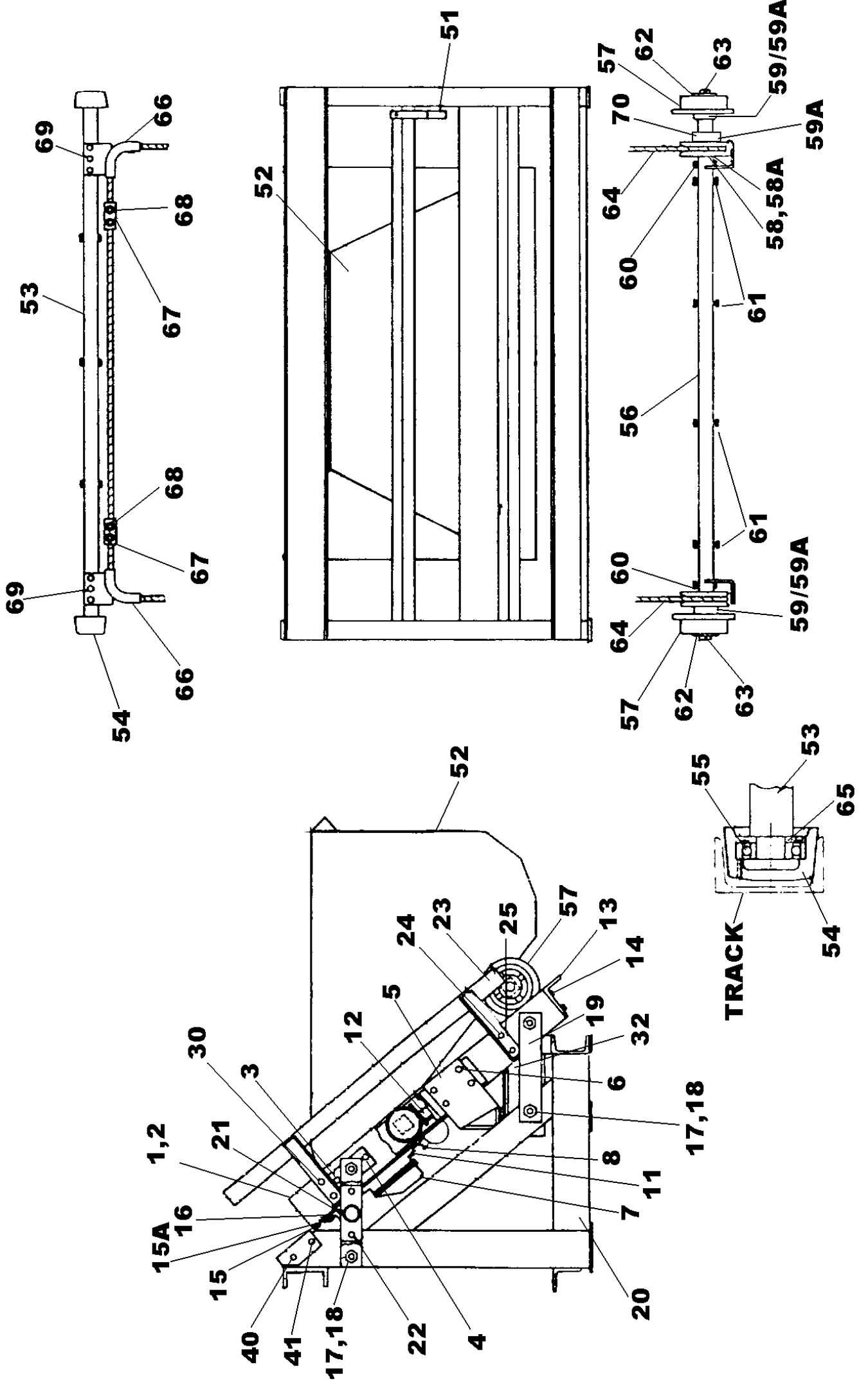

RP550XD ARRANGEMENT OF WEIGHER & LOADING HOPPER

1	CR260338	Runway Opp. Limit Switch Side	1
2	CR260338	Runway Limit Switch Side	1
3	CR260062	Runway Hinge Pin	2
4	52S06G	Runway Hinge Pin C/Sunk Bolts M16 x35	4
4A	267S09	Washer Flat M16	4
4B	17S08	Washer Spring M16	4
4C	7S06	Nut M16	4
5	CR260334	Bridge	1
6	11S06G	Bridge Screw Sets M16 x 45	8
6A	267S09	Washer Flat M16	8
6B	17S08	Washer Spring M16	8
6C	7S06	Nut M16	8
7	CR220005	Limit Switch, NLA use CR229083	1
8	CR220100	Limit Switch Arm, NLA use CR229083	1
9	CR530450	Limit Switch Plate	1
10	52S05H	Limit Switch Plate C/Sunk Screws M12 x 40	4
10A	17S06	Washer Spring	4
10B	7S05	Nut	4
11	8S03D	Limit Switch Securing bolts (for CR220100) M8 x 40	4
11A	267S05	Washer Flat M8	8
11B	17S04	Washer Spring M8	4
11C	7S03	Nut M8	4
11D	8S01D	Limit Switch Securing bolts (for CR229083) M5 x 40	4
11E	17S02	Washer Spring M5	4
11F	7S01	Nut M5	4
12	CR260065	Hopper stop	1PR
13	CR260335	Runway Tie	1
14	8S06D	Runway Tie Bolts M16 X 40	4
14A	267S09	Washer Flat M16	4
14B	17S08	Washer Spring M16	4
14C	7S06	Nut M16	4
15	CR260337	Runway Brace	2
15A	8S06D	Runway Brace Bolts M16 X 40	4
15B	267S09	Washer Flat M16	4
15C	17S08	Washer Spring M16	4
15D	7S06	Nut M16	4
16	52S06J	Runway Brace C/Sunk Screws M16 x 45	4
16A	267S09	Washer Flat M16	4
16B	17S08	Washer Spring M16	4
16C	7S06	Nut M16	4
17	8S08T	Link Bolts M24 x 140	6
17A	267S12	Washer Flat M24	14
17B	17S11	Washer Spring M24	8
17C	7S08	Nut M24	6
18	CR180014	Rubber Bearing Silentbloc	8
19	CR260063	Link	4
20	CR260154	Weigher Frame	1
21	CR260064	Torque Tube (state machine number)	1
22	8S06G	Torque Tube Bolts M16 x 55	4
22A	267S09	Washer Flat M16	4
22B	17S08	Washer Spring M16	4
22C	7S06	Nut M16	4
23	CR260336L	Guide Rail Left Hand	1

RP550XD ARRANGEMENT OF WEIGHER & LOADING HOPPER

23A	CR260336R	Guide Rail Right Hand	1
24	11S05F	Guide Rails Screw Set M12 X 40 (Lower)	4
24A	267S07	Washer Flat M12	4
24B	17S06	Washer Spring M12	4
24C	7S05	Nut M12	4
25	CR530600	Guide Rail Packings	4
30	52S05J	Guide Rails C/Screw M12 X 45 (Upper)	4
30A	267S07	Washer Flat M12	4
30B	17S06	Washer Spring M12	4
30C	7S05	Nut M12	4
40	8S06D	Runway Bolts M16 X 40	4
40A	267S09	Washer Flat M16	4
40B	17S08	Washer Spring M16	4
40C	7S06	Nut M16	4
41	52S06G	Runway C/Sunk Bolts M16 x35	4
41A	267S09	Washer Flat M16	4
41B	17S08	Washer Spring M16	4
41C	7S06	Nut M16	4
51	CR540344	Limit Swtich Striker	1
52	CR541293	Loading Hopper (550/850)	1
53	CR520131	Loading Hopper Front Axle	1
54	CR21100097	Loading Hopper Front Axle Roller	2
55	CR150844	Loading Hopper Front Axle Roller Bearing	2
56	CR520132	Rear Axle	1
57	CR210157	Rear Axle Roller	2
58	CR210160	Rear Axle Rope Pulley	2
58A	267S13	Waher Flat, M48 Rope Pulley	2
59	CR630209	Rear Axle Collar	2
59A	57S05D2	Screw Grub Rear Axle Collar M8 x 10	3
60	8S05L	Rear Axle Bolts Short M12 x 75	2
60A	17S06	Washer Spring M12	2
60B	7S05	Nut M12	2
61	8S05N	Rear Axle Bolts Long M12 X 90	4
61A	17S06	Washer Spring M12	4
61B	7S05	Nut M12	4
62	10S43	Rear Axle Flat Washer 1.5"	2
63	44S06L	Rear Axle Split Pin	2
64	CR350008	Hopper Rope (when ordering quote machine no:)	1
65	CR530602	Front Axle Washer	2
66	CR260436	Front Axle Rope Guide	2
67	CR530603	Front Axle Rope Retainer Block	2
68	CR530587	Front Axle Rope Anchor Bolts (Special)	4
69	8S05L	Front Axle Rope Anc. Guide Bolts M12 x 75	6
69A	17S06	Washer Spring M12	6
69B	7S05	Nut M12	6
70	CR639010	Collar, Rope Pulley Retaining	1
FIXINGS FOR ELECTRONIC LOADCELL (NOT ILLUSTRATED)			
71	8S06D	Bolts M16 X 40	4
71A	267S09	Washer Flat M16	4
71B	17S08	Washer Spring M16	4
71C	7S06	Nut M16	4
ELECTRONIC LOADCELL & DIGITAL READOUT BOX (NOT ILLUSTRATED)			
72	CR179022	Loadcell	1
73	CR179028	Indicator, Digital Readout Box	1

RP550XD WHIRLER ASSEMBLY (MOTOR UP)

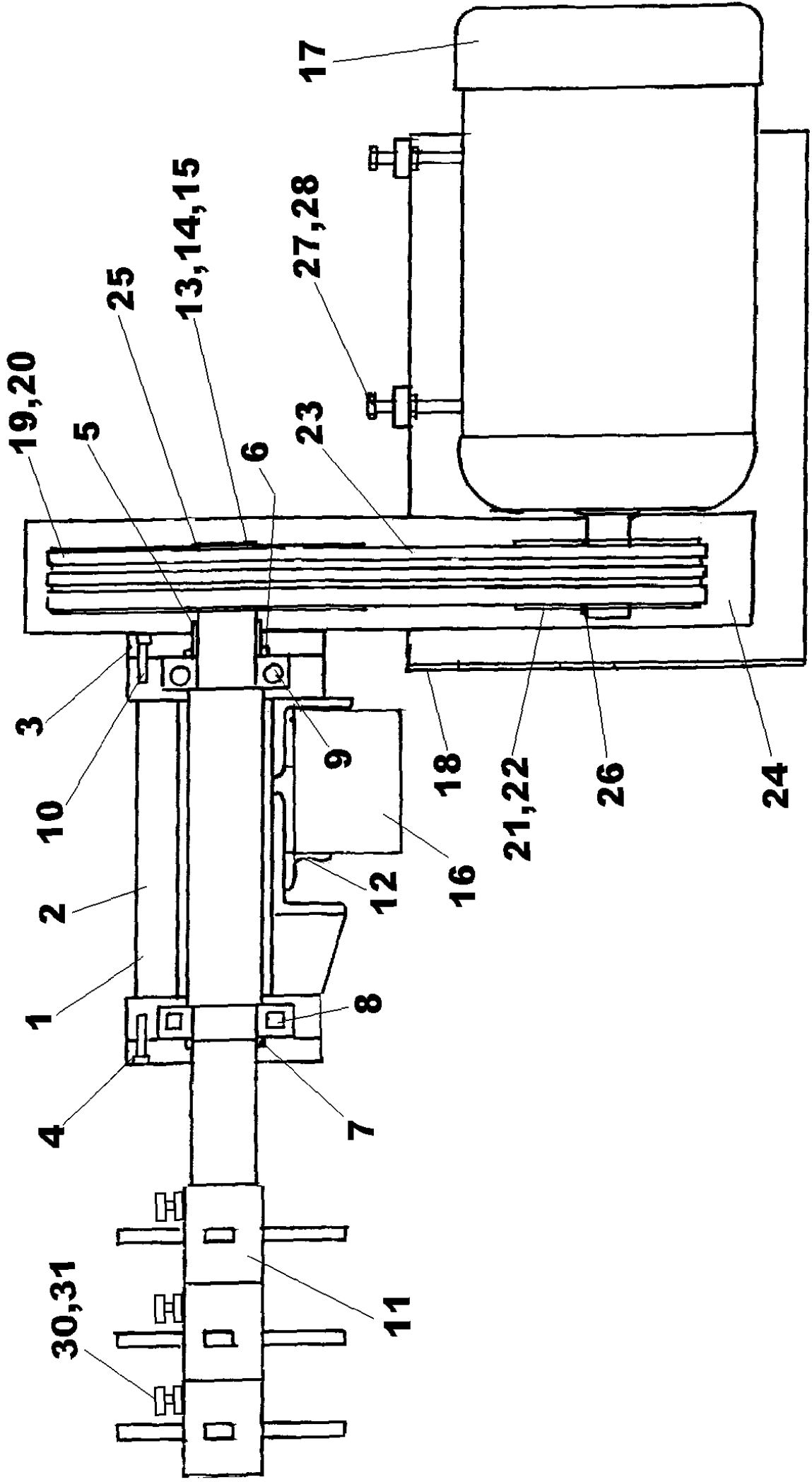

RP550XD WHIRLER ASSEMBLY (MOTOR UP)

1	CR520520	Whirler Shaft	1
2	CR261471	Bearing Housing	1
2A	131S01	Nipple Grease	1
2B	176S01	Cover Nipple Grease	2
3	CR532110	Bearing Cap	2
4	CR532111	Bearing Cap	1
5	CR532109	Spacer	1
6	CR569014	Lip Seal	1
7	CR569016	Lip Seal	1
8	CR150701	Bearing	1
9	CR150538	Bearing	1
10	68S05G	Cap Screw M10 x 40	1
11	CR219006	Blade Square Whirler, Cast	3
11	CR219006SS	Blade Square Whirler, Stainless Steel	3
11	CR219006SSA	Blade Square Whirler, Stainless Steel, Angled	3
11	CR219006H	Blade Square Whirler, Tungsten Carbide Coated	3
11	CR219006AH	Blade Square Whirler, Tungsten Carbide Coated, Angled	3
11	CR219017	Blade Square Whirler, Two Blades, Tungsten Carbide Coated	A/R
12	CR532112	Mounting Angle	1
13	CR539005	Retaining Washer	3
14	11S05F	Screw Set M12	1
15	17S06	Washer Spring M12	1
16	CR269211	Whirler Mounting Bracket	1
17	CR220102	Motor	1
18	CR269212	Bracket Motor Mounting	1
19	CR340550	Pulley Whirler	1
20	CR340551	Bush Taperlock	1
21	CR340552	Pulley Motor	1
22	CR340546	Bush Taperlock	1
23	CR169002	V Belts	1
24	CR519151	Belt Guard	3
25	CR329001	Key Parrallel 18 x 11 x 60	1
26	CR329000	Key Parrallel 12 x 8 x 60	3
27	11S05M	Screw Set Motor Adjusting M12 x 70	2
28	7S05	Nut M12	2
30	11S05F	Screw Blade Retaining M12	3
31	7S05	Nut M12	3

RP550XD WHIRLER ASSEMBLY (MOTOR UP 460V 3PH 60HZ)

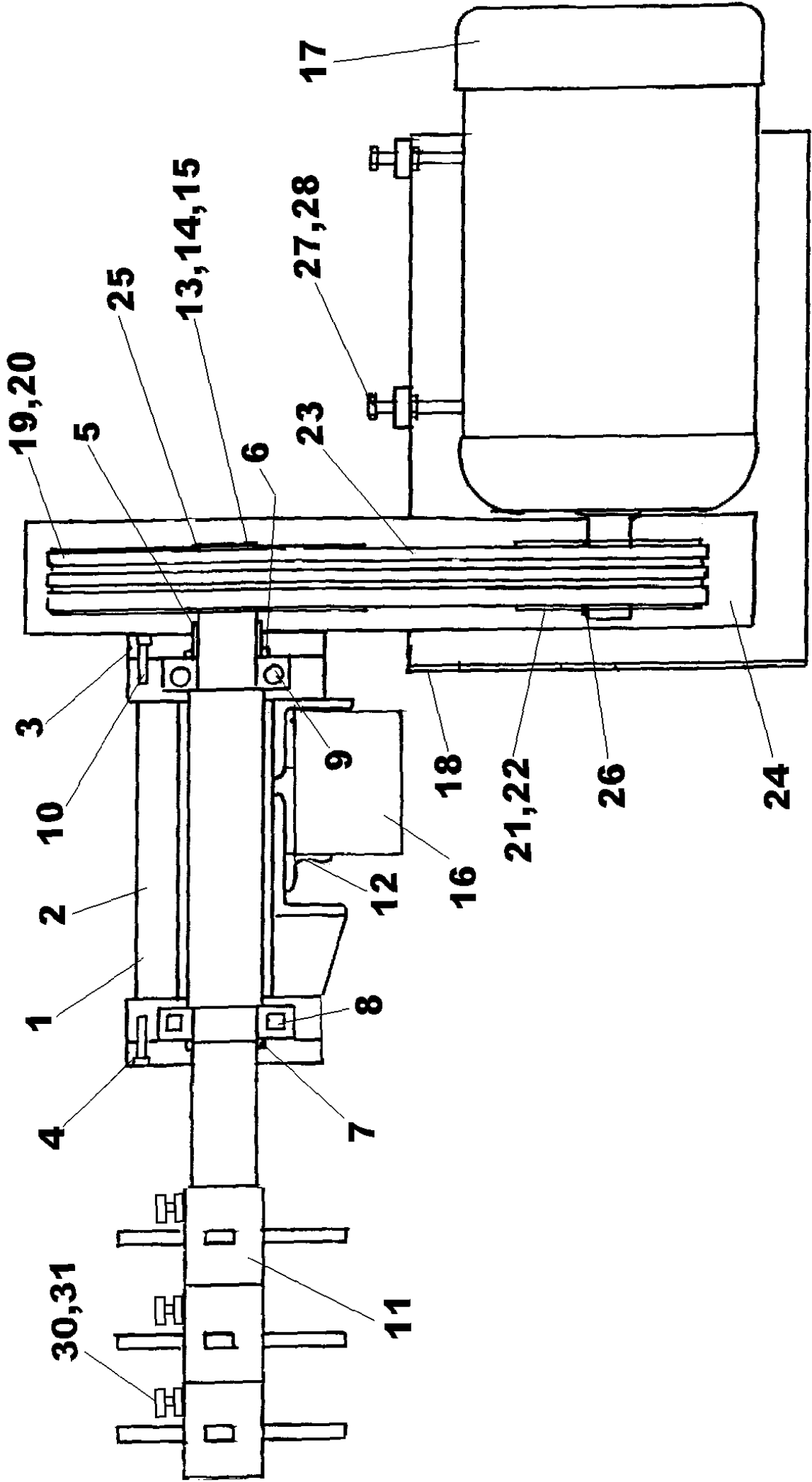

RP550XD WHIRLER ASSEMBLY (MOTOR UP 460V 3PH 60HZ)

1	CR520520	Whirler Shaft	1
2	CR261471	Bearing Housing	1
2A	131S01	Nipple Grease	1
2B	176S01	Cover Nipple Grease	2
3	CR532110	Bearing Cap	2
4	CR532111	Bearing Cap	1
5	CR532109	Spacer	1
6	CR569014	Lip Seal	1
7	CR569016	Lip Seal	1
8	CR150701	Bearing	1
9	CR150538	Bearing	1
10	68S05G	Cap Screw M10 x 40	1
11	CR219006	Blade Square Whirler, Cast	3
11	CR219006SS	Blade Square Whirler, Stainless Steel	3
11	CR219006SSA	Blade Square Whirler, Stainless Steel, Angled	3
11	CR219006H	Blade Square Whirler, Tungsten Carbide Coated	3
11	CR219006AH	Blade Square Whirler, Tungsten Carbide Coated Angled	3
11	CR219017	Blade Square Whirler, Two Blades, Tungsten Carbide Coated	A/R
12	CR532112	Mounting Angle	1
13	CR539005	Retaining Washer	3
14	11S05F	Screw Set M12	1
15	17S06	Washer Spring M12	1
16	CR269211	Whirler Mounting Bracket	1
17	CR229086	Motor Electric 460 Volt 3Ph 60Hz	1
18	CR269213	Bracket Motor Mounting	1
19	CR340550	Pulley Whirler	1
20	CR340551	Bush Taperlock	1
21	CR340552	Pulley Motor	1
22	CR340546	Bush Taperlock	1
23	CR169002	V Belts	1
24	CR519151	Belt Guard	3
25	CR329001	Key Parallel 18 x 11 x 60	1
26	CR329000	Key Parallel 12 x 8 x 60	3
27	11S05M	Screw Set Motor Adjusting M12 x 70	2
28	7S05	Nut M12	2
30	11S05F	Screw Blade Retaining M12	3
31	7S05	Nut M12	3

RP550XD SPLIT SHAFT WHIRLER

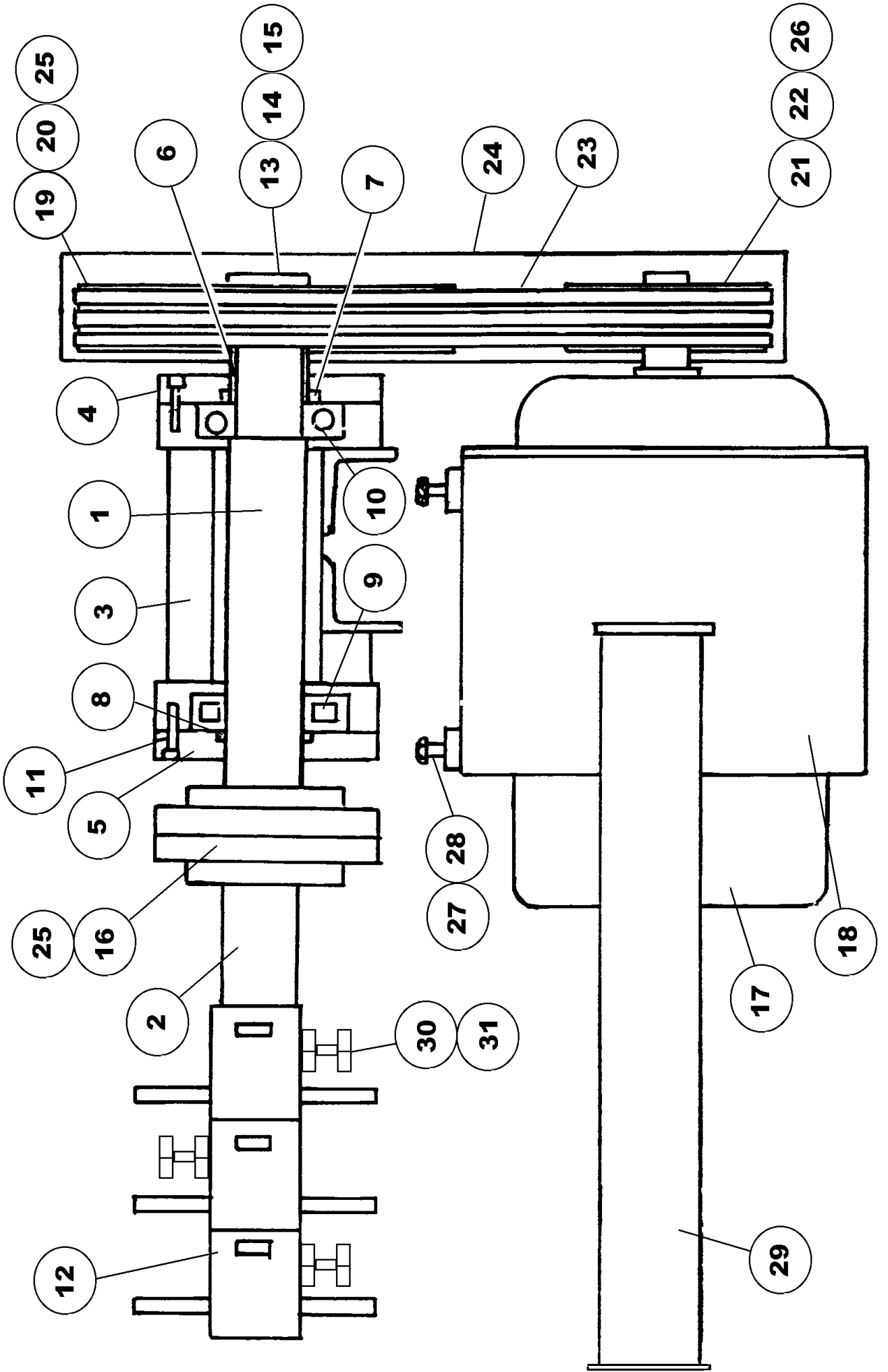

RP550XD SPLIT SHAFT WHIRLER ASSEMBLY

1	CR529154	Whirler Top Shaft	1
2	CR529155	Whirler Lower Sft	1
3	CR269163	Bearing Housing	1
3A	131S01	Nipple Grease	2
3B	176S01	Cover Nipple Grease	2
4	CR532110	Bearing Cap Upper	1
5	CR532111	Bearing Cap Lower	1
6	CR532109	Spacer Bearing	1
7	CR569014	Lip Seal Upper	1
8	CR569016	Lip Seal Lower	1
9	CR150701	Bearing	1
10	CR150538	Bearing	1
11	68S05G	Cap Screw M10 x 40	6
12	CR219006	Blade Square Whirler, Cast	3
12	CR219006SS	Blade Square Whirler, Stainless Steel	3
12	CR219006SSA	Blade Square Whirler, Stainless Steel, Angled	3
12	CR219006H	Blade Square Whirler, Tungsten Carbide Coated	3
12	CR219006AH	Blade Square Whirler, Tungsten Carbide Coated, Angled	3
12	CR219017	Blade Square Whirler, Two Blades, Tungsten Carbide Coated	A/R
13	CR539005	Retaining Washer	1
14	11S05F	Screw Set M12	1
15	17S06	Washer Spring M12	1
16	CR239026	Coupling Rigid	1
16A	11S06L	Screw Set M16	6
16B	17S08	Washer Spring M16	6
17	CR220102	Motor Electric	1
17A	8S05G	Bolt M12	4
17B	7S05	Nut M12	4
17C	17S06	Washer Spring M12	4
17D	267S07	Washer Flat M12	4
18	CR269180	Bracket Motor Bedplate	1
19	CR340550	Pulley	1
20	CR340551	Bush Taperlock	1
21	CR340552	Pulley	1
22	CR340546	Bush Taperlock	1
23	CR160060	V Belts	3
24	CR549137	Belt Guard	1
25	CR329001	Key Parallel 18 X 11 X 60	1
26	CR329000	Key Parallel 12 X 8 X 60	1
27	11S05M	Bolt Belt Adjusting M12 x 70	2
28	7S05	Nut M12	2
29	CR539166	Support Strut	1
30	11S05F	Screw Blade Retaining M12	3
31	7S05	Nut M12	3

RP550XD WIRE ROPE RENEWAL PROCEDURE

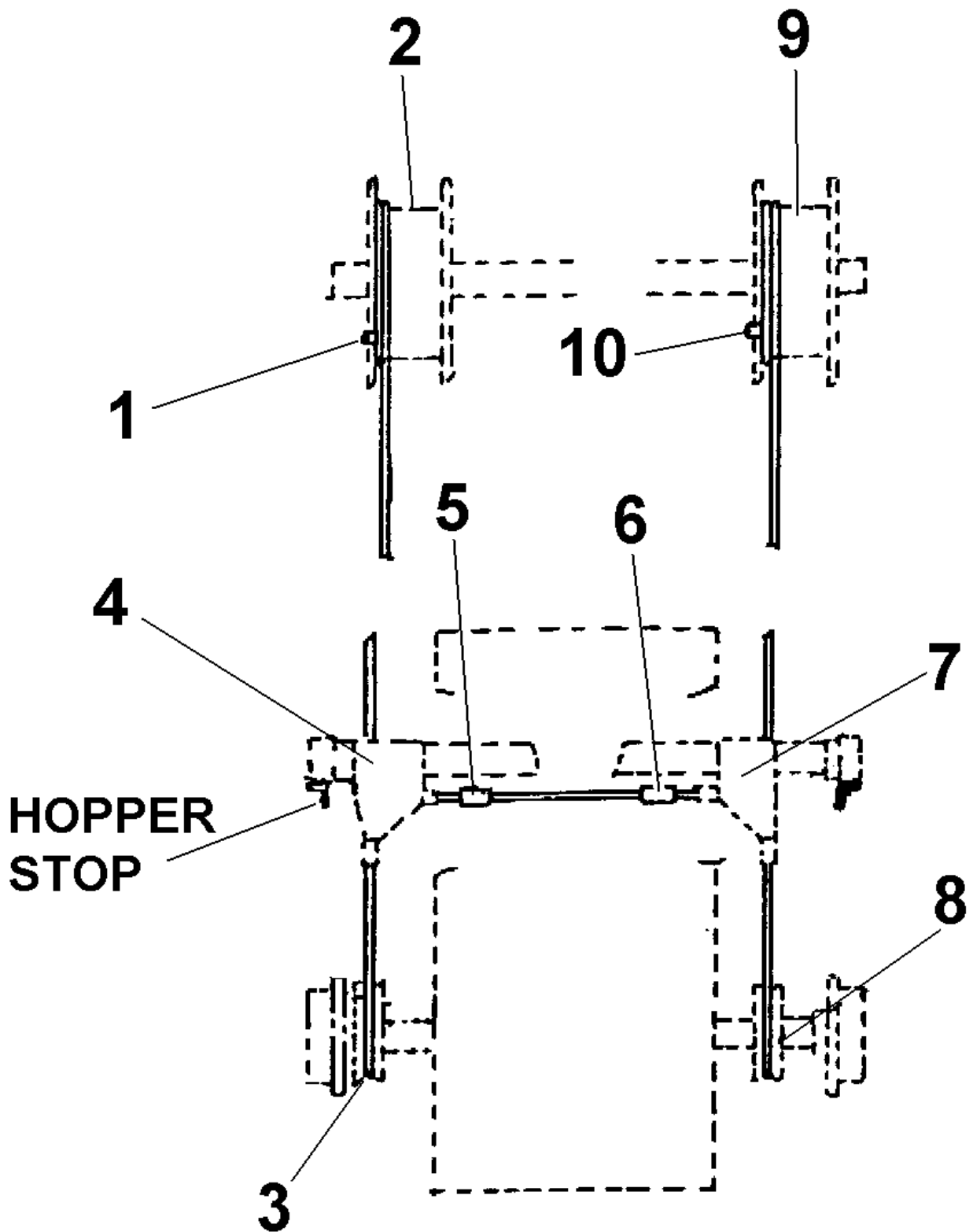

CROKER LOADER

WIRE ROPE RENEWAL PROCEDURE

1. Place the Hopper on the hopper stops. Loosen nut from rope anchor bolt, item 1, on one rope drum only, item 2.
2. Remove end of old wire rope from anchor bolt.
3. Fit end of new wire rope to anchor bolt and tighten nut.
4. Lay other end of new wire rope end to end with old wire rope removed in part 2. Bind both ends together with sticky tape (electrical or masking tape).
5. Carefully pull on the old wire rope to pull the new wire down to the bottom of the hopper and around the rear axle rope pulley, item 3, and up through the front axle rope guide, item 4.
6. Remove front axle rope retainer blocks, items 5 and 6, and slide onto the new rope.
7. Continue to pull the wire and thread through the second rope guide, item 7, and down around the second rope pulley, item 8, and up to the second rope drum, item 9.
8. Remove old wire from second anchor bolt, item 10, on second rope drum, item 9, and remove tape from ends of old and new wire.
9. Fit second end of new wire to second anchor bolt, item 10, on second rope drum, item 9.
10. Tighten anchor bolt nuts on both rope drums.
11. The new wire should now run over the front edges of both rope drums and down to front edges of both the lower axle rope pulleys, items 3 and 8, and up the back of the rope pulleys to the rope guides, items 4 and 7, with both rope retainer blocks, items 5 and 6, located on the section of wire rope between the two rope guides at the back of the hopper.
12. Start and stop the loader by hand, using the start and stop buttons, and take out all the slack of the wire rope in the raise direction (see important note on page 30), ensuring that the wire slots into both axle rope pulleys, item 2 and 9, and that the wire has wound evenly onto both rope drums. Make sure the hopper is level and sitting on weigher track stops before

positioning rope retainer blocks, items 5 and 6, approximately 2 inches (50 mm) in board of rope guides, item 4 and 7, each side and make fast retainer blocks onto wire.

13. Check that both limit switches are working correctly and the magnetic brake applies correctly.
14. Make sure hopper clears both sides of rope drums at the top of its operation.

NOTE: Hopper reaches end of travel between rope drums.

IMPORTANT NOTE

Ensure that the slack wire is taken up in the raise direction and not the lowering direction. If the rope is wound incorrectly in the reverse direction on to the rope drums the hopper will not stop at the upper limit switch. It will continue until it makes contact with the top of the structure and will continue to heave until the wire rope breaks, with the result , if both sides of the wire fail at the same time, that the hopper will drop to the bottom end of the skip track.

WIRE ROPES

SAFETY NOTES

ALWAYS

Store and handle the wire rope correctly, wear protective gloves and eye protection.

Check the rope test certificate is still in date especially if the rope has been in storage also check that the certificate is applicable to the rope.

Remove the rope from any reel or coil correctly and without kinking.

Only use correct end terminations and rope anchors.

Ensure that the rope is correctly located and seated on the rope drum.

Ensure that the rope is correct for the application and only use good quality ropes from reputable suppliers.

Inspect the wire rope for damage, wear, corrosion or abuse at the start of each shift.

Keep the wire rope clean and maintained in accordance with the manufacturers instructions.

NEVER

Try to shorten any wire rope by knotting.

Bend a wire rope over small radii.

Subject wire ropes to shock loadings.

Allow wire ropes to run over sharp edges or abrasive surfaces etc.

Subject wire ropes to extremes of temperature.

Use wire ropes with obvious signs of mechanical, corrosive or heat damage.

Use wire ropes that are worn, frayed, split or corroded.

STORAGE

Store wire ropes in a clean well ventilated, dry location preferably undercover and protected from extremes of temperatures.

If site conditions are such that undercover storage is not possible cover the rope with a waterproof cover and support clear of the ground.

Rotate stored wire ropes, reels or coils regularly to prevent migration of the rope lubricant, particular in warm environments.

Be aware that subjecting wire ropes to extremes of temperature as can affect the in service performance, high storage temperatures can reduce the effective strength of the rope.

SAFETY

Running wire ropes are hazardous and should be guarded or personnel should be prevented access to them whilst in motion.

Wire ropes develop broken strands during their working life which present a hazard to maintenance personnel, always wear suitable hand and eye protection when handling ropes.

Take care when unfastening a coiled rope as the inherent springiness when released may cause it to strike attendant personnel or other equipment causing damage or injury.

Take care when removing worn, damaged or failed ropes from equipment as they may be tightly coiled, grossly distorted and still retain their springiness.

IN SERVICE INSPECTION AND MAINTENANCE

Wire ropes used for lifting operations should be regularly inspected by a competent person and inspection records kept upto date.

Inspections should not only concentrate on the rope but also extend to the condition of sheaves, drums, guides etc.

Decisions on whether a wire rope is suitable for continued service should only be made by a competent person.

IF IN DOUBT REPLACE THE ROPE.

PAGE INTENTIONALLY BLANK

PAGE INTENTIONALLY BLANK

PAGE INTENTIONALLY BLANK

PAGE INTENTIONALLY BLANK

PAGE INTENTIONALLY BLANK

PAGE INTENTIONALLY BLANK

RP550XD BOTTOM DISCHARGE LOADING HOPPER

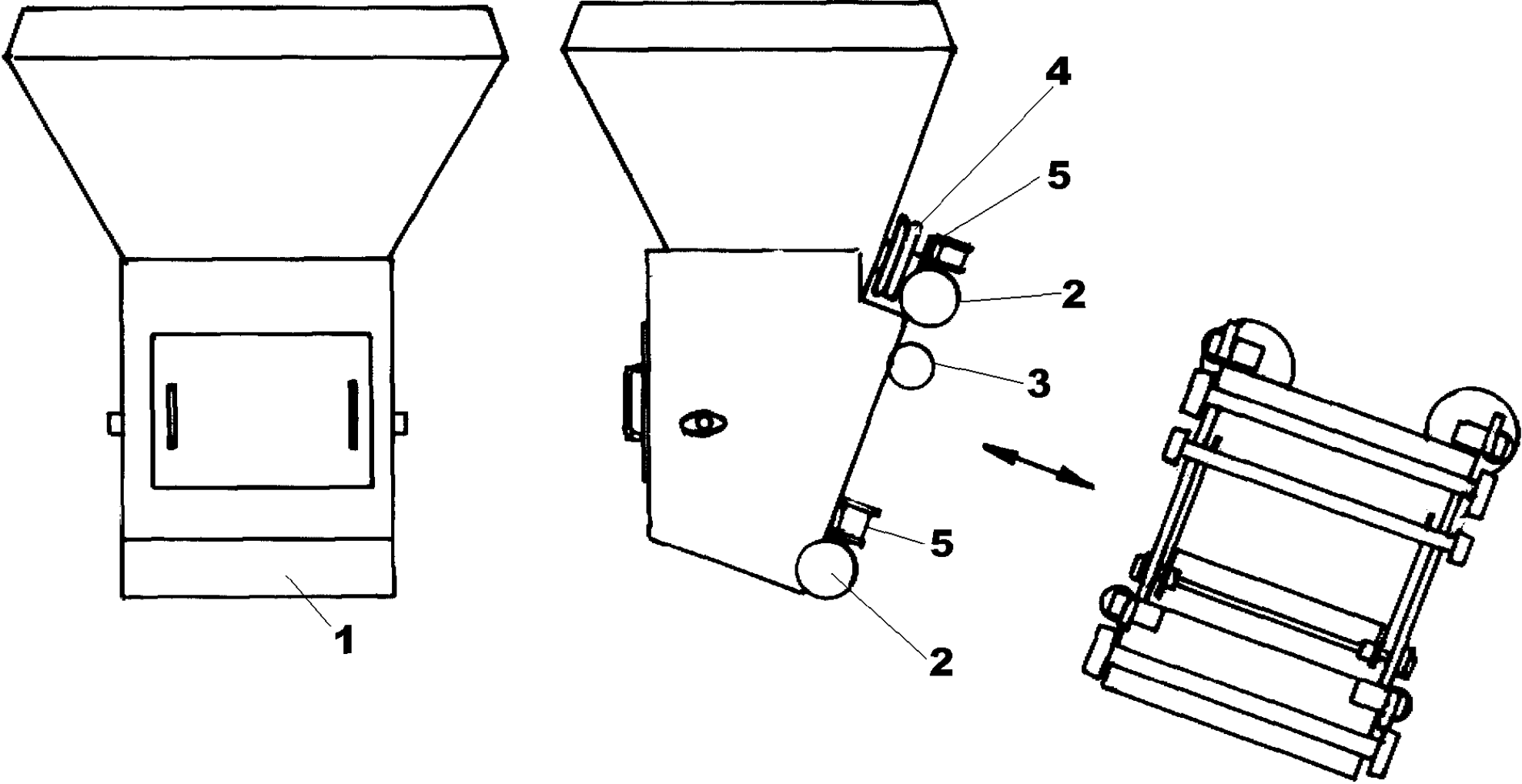

RP550XD BOTTOM DISCHARGE LOADING HOPPER

1	CR54100527	Loading Hopper Assembly	1
2	CR089041	Axle Assembly	2
3	CR089042	Door Assembly	1
4	CR089043	Pulley Assembly	2
5	CR089044	Side Roller Assembly	4

RP550XD AXLE ASSEMBLY BOTTOM DISCHARGE HOPPER

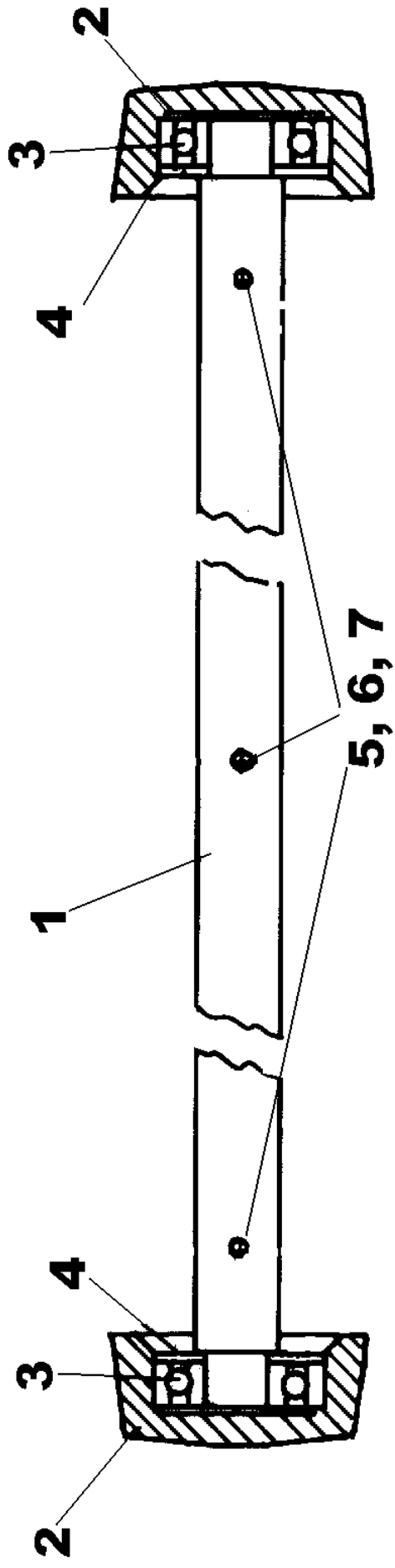

RP550XD AXLE ASSEMBLY BOTTOM DISCHARGE HOPPER

1	CR529161	Axle Shaft	1
2	CR210015	Track Wheel	2
3	CR159015	Bearing	2
4	C539130	Axle Shaft Washer	2
5	8S06N	Bolt M16 x 90	3
6	17S08	Washer Spring M16	3
7	7S06	Nut M16	3

RP550XD DOOR ASSEMBLY BOTTOM DISCHARGE HOPPER

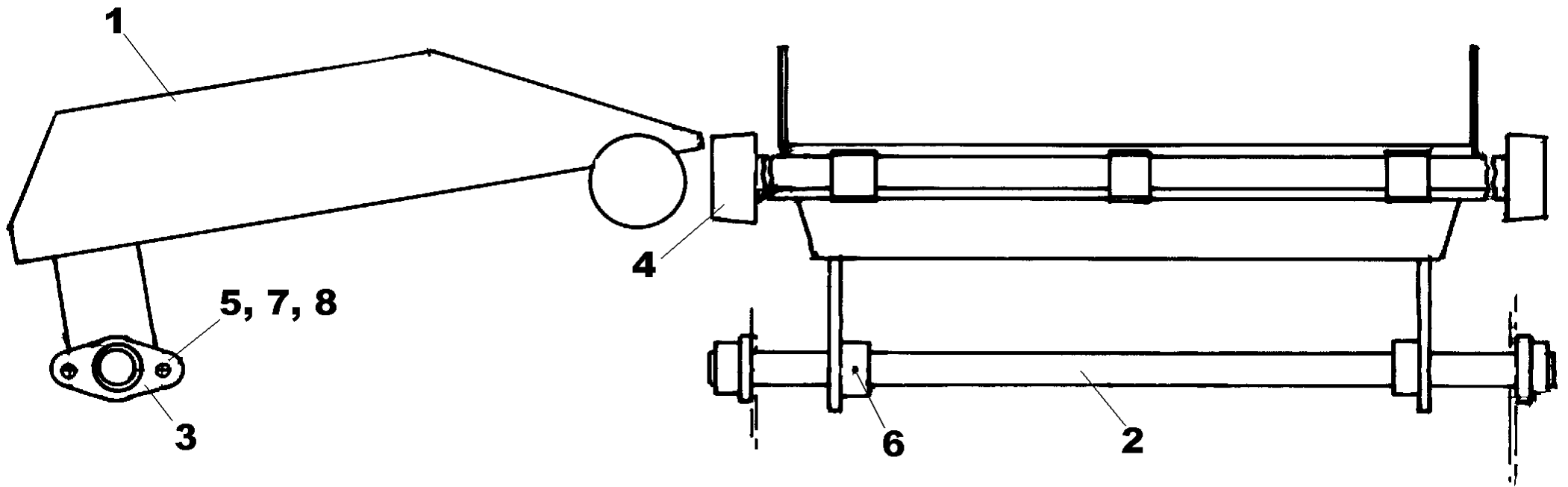

RP550XD DOOR ASSEMBLY BOTTOM DISCHARGE HOPPER

1	CR269238	Door Discharge	1
2	CR529162	Pivot Shaft	1
3	CR159017	Bearing	2
4	CR089040	Guide Shaft Assembly	1
5	11S05E	Screw Set M10 x 35	2
6	57S07F1	Screw Grub M12 x 16	2
7	7S05	Nut M10	4
8	17S05	Washer Spring M10	4

RP550XD GUIDE SHAFT ASSEMBLY BOTTOM DISCHARGE HOPPER

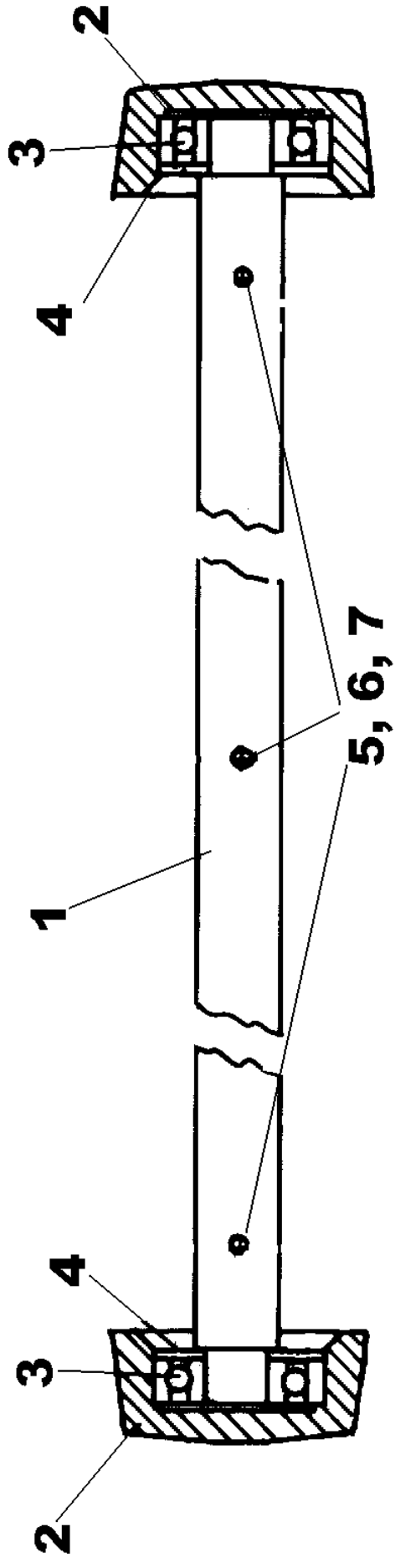

RP550XD GUIDE SHAFT BOTTOM DISCHARGE HOPPER

1	CR529163	Guide Shaft	1
2	CR210156	Guide Shaft Wheel	2
3	CR150844	Bearing	2
4	CR530602	Guide Shaft Washer	2
5	8S04J	Bolt M10 x 65	3
6	17S05	Washer Spring M10	3
7	7S04	Nut M10	3

RP550XD PULLEY BOTTOM DISCHARGE HOPPER

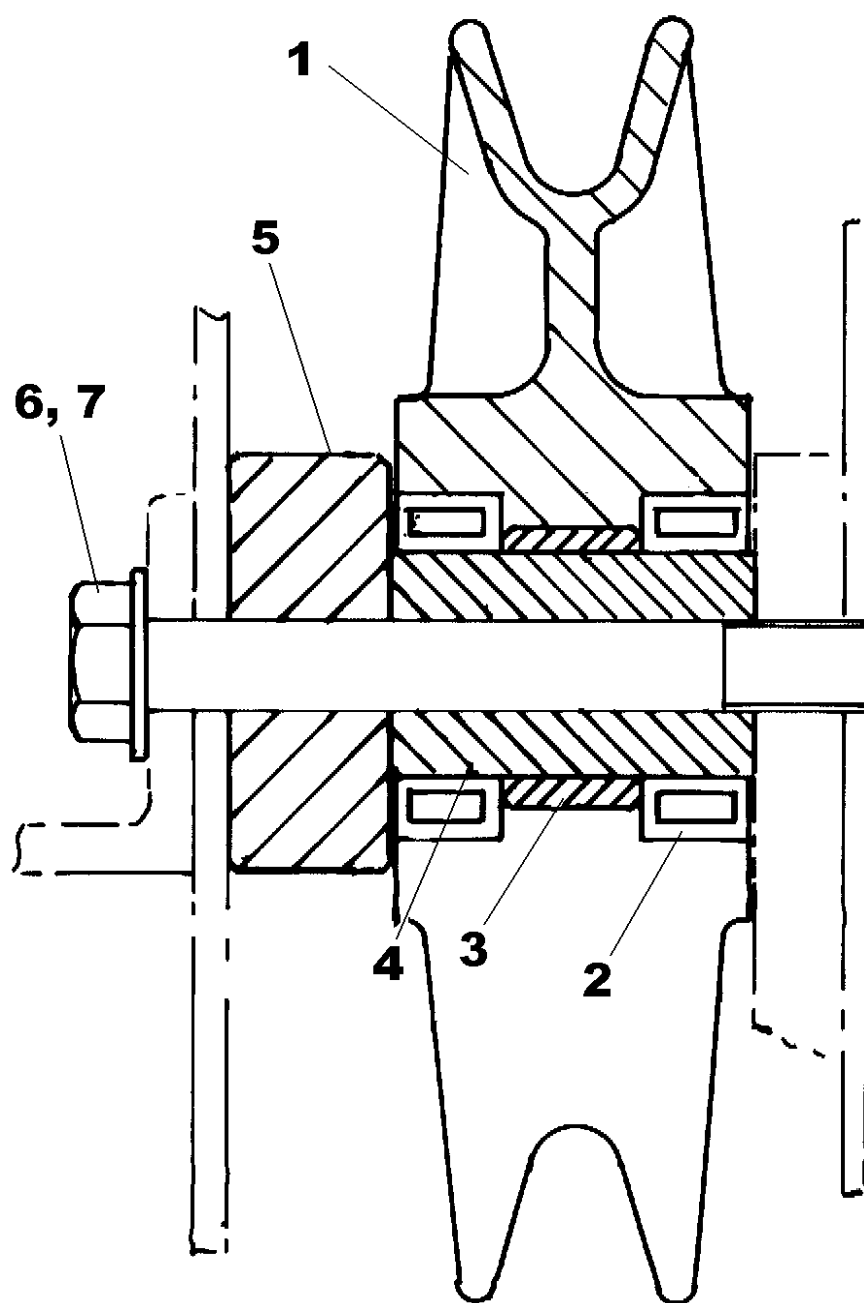

RP550XD PULLEY BOTTOM DISCHARGE HOPPER

1	CR219015	Pulley	1
2	CR159018	Bearing	2
3	CR529165	Spacer	1
4	CR529006	Bush	1
5	CR539218	Pulley Spacer	1
6	8S07EE	Bolt M20 x 160	1
7	17S09	Washer Spring M20	1

RP550XD SIDE ROLLER BOTTOM DISCHARGE HOPPER

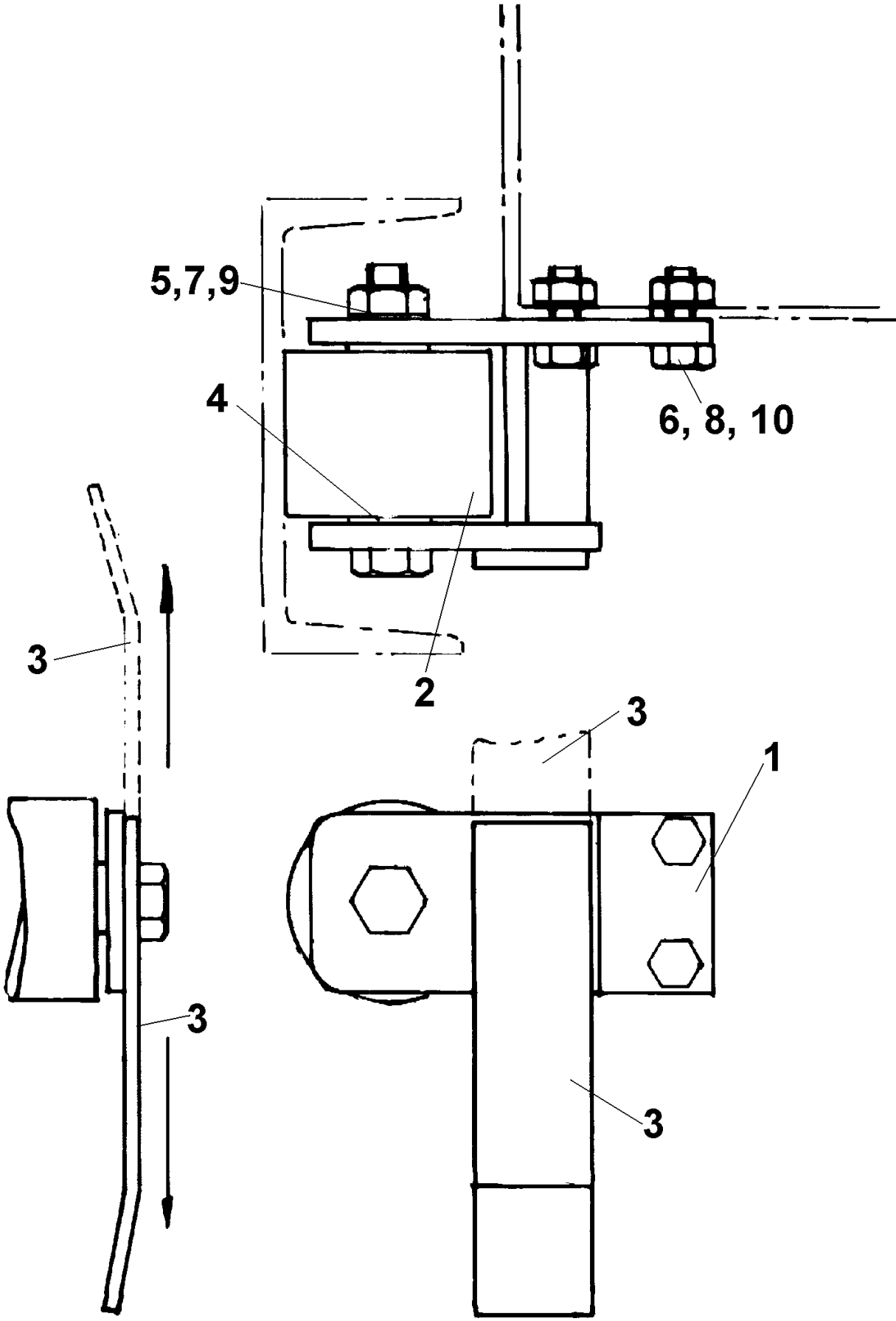

NOTE
LIMIT SWITCH OPERATING LEVER ITEM 3 FACES:-
DOWN FOR LOWER SIDEROLLERS
UP FOR UPPER SIDE ROLLERS

RP550XD SIDE ROLLER BOTTOM DISCHARGE HOPPER

1	CR26100531	Bracket Side Roller	1
2	CR449003	Side Roller	1
3	CR53100561	Limit Switch Lever	1
4	267S	Washer Flat M20	2
5	8S07Q	Bolt M20 x 110	1
6	11S04C	Screw Set M10 X 25	4
7	7S07	Nut M20	1
8	7S04	Nut M10	4
9	17S09	Washer Spring M20	1
10	17S05	Washer Spring M10	4

RP550XD LOADER FRAME ASSEMBLY BOTTOM DISCHARGE HOPPER

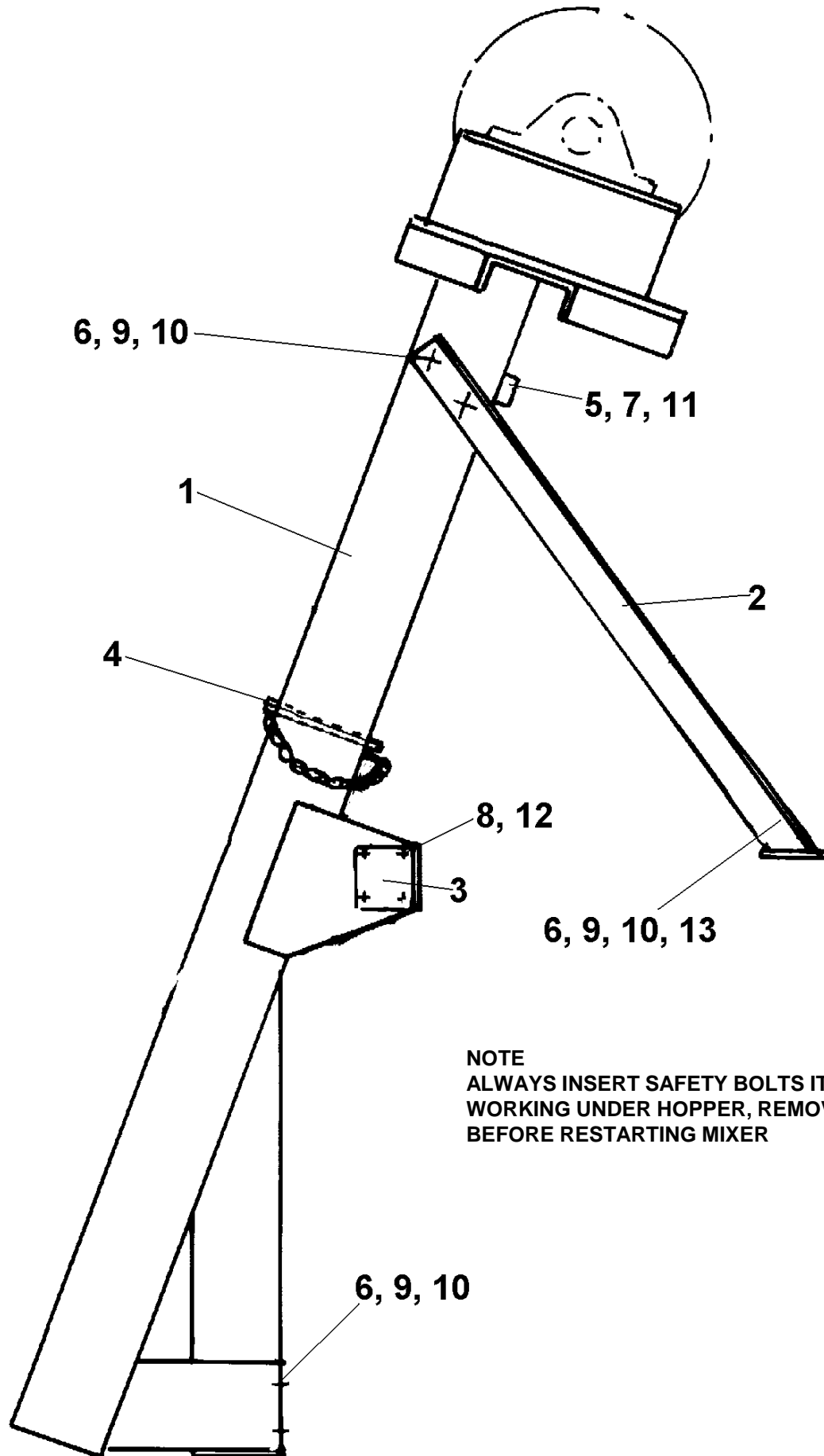

NOTE
ALWAYS INSERT SAFETY BOLTS ITEM 4 BEFORE
WORKING UNDER HOPPER, REMOVE BOLTS
BEFORE RESTARTING MIXER

RP550XD LOADER FRAME BOTTOM DISCHARGE HOPPER

1	CR269239	Loader Frame Assembly	1
2	CR269240	Brace Top	1
3	CR62006/4	Plate Caution	2
4	CR530062	Safety Bolt	2
5	CR229083	Limit Switch	2
6	V2003598	Bolt M16 x 40	14
7	11S01F	Screw Set M5 x 40	8
8	11S02A	Screw Set M6 x 16	8
8A	267S04	Washer Flat M6	16
9	7S06	Nut M16	14
10	17S08	Washer Spring M16	14
11	17S02	Washer Spring M5	8
12	17S03	Washer Spring M6	8
13	105S07	Washer Tapered M16	2

RP550XD LOADER DRIVE BOTTOM DISCHARGE HOPPER

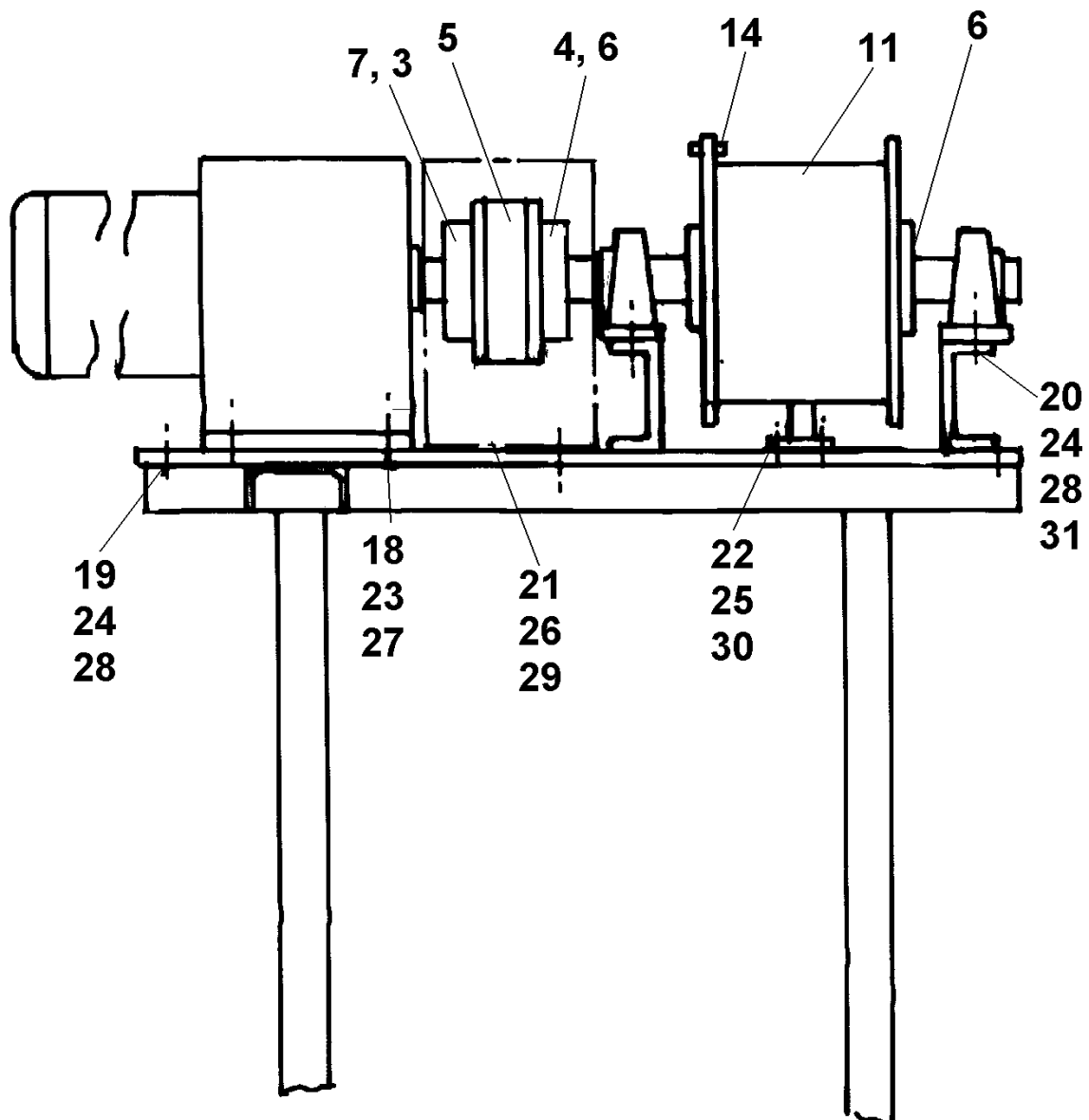
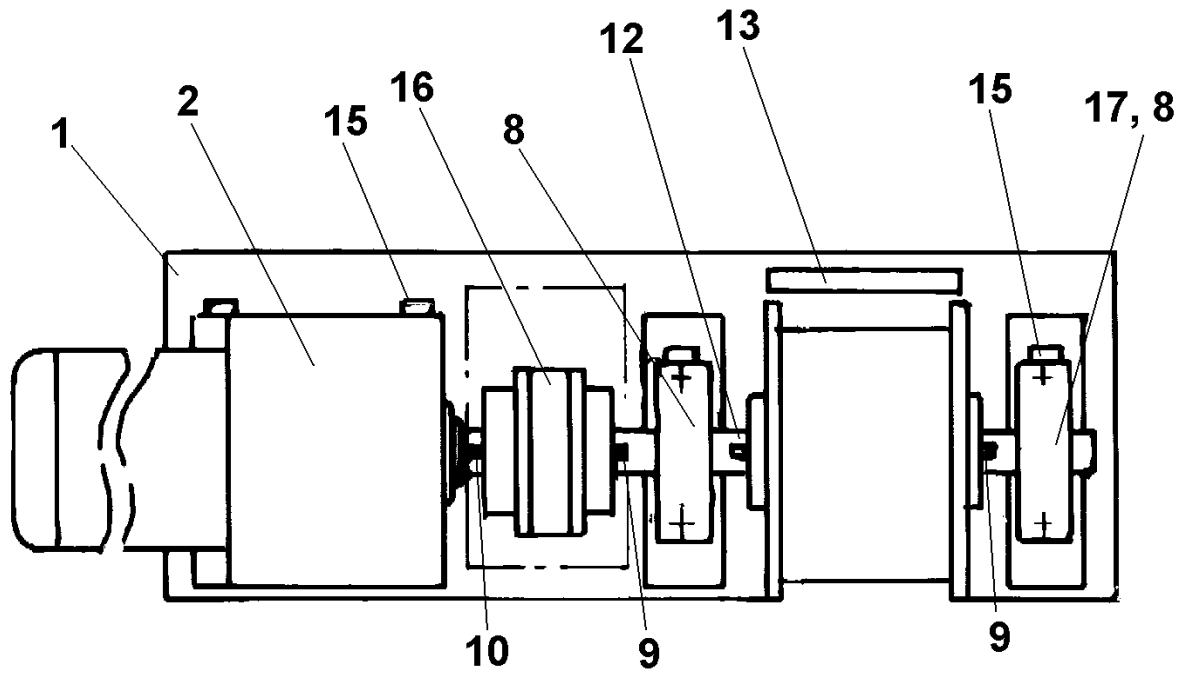

RP550XD LOADER DRIVE BOTTOM DISCHARGE HOPPER

1	CR269239	Loader Frame Assembly	1
2	CR299128	Gearbox Unit	1
3	CR239000	Drive Shaft Coupling	1
4	CR239001	Drive Shaft Coupling	1
5	CR239002	Standard Element	1
6	CR239003	Taper Lock Bush	3
7	CR239021	Taper Lock Bush	1
8	CR159005	Bearing	2
9	CR239045	Key	3
10	CR23905	Key	1
11	CR219005	Cable Drum	1
12	CR529042	Drive Shaft	1
13	CR269155	Rope Keep Bar	1
14	CR530064	Rope Anchor Bolts	2
15	CR269067	Shear Blocks	4
16	CR549131	Coupling Guard	1
17	CR539228	Shims	6
18	8S13R	Bolt M30 x 120	4
19	8S07F	Bolt M20 x 50	9
20	8S07N	Bolt M20 x 90	4
21	8S02B	Bolt M6 x 30	6
22	8S05F	Bolt M12 x 50	2
23	7S11	Nut M30	4
24	7S07	Nut M20	13
25	7S05	Nut M12	2
26	7S02	Nut M6	6
27	267S14	Washer Flat M30	4
28	17S09	Washer Spring M20	13
29	17S03	Washer Spring M6	6
30	17S06	Washer Spring M12	2
31	105S09	Washer Tapered M20	4

**OPERATING
AND
MAINTENANCE MANUAL**

SECTION 6

ELECTRICAL SYSTEM

ELECTRICAL INFORMATION

1. The mixing pan and mixing star motors should be interconnected in the control to operate at the same time, as it is important that both are working before a mix is added. Ensure that suitable overloads are fitted. The mixing pan and mixing star rotate anti-clockwise when looking from the top.

NOTE: With motors 5.5 kw and above, use Star Delta Starters. Below this, use Direct on Line Starters.

2. When a loader is attached a direct on line reversing starter is required complete with suitable overloads. The loader winch rotates anti-clockwise looking from the rope drum end and when the raise button is pressed.

The upper and lower limit switches are positioned to break the electrical supply to the loader motor when the loading hopper is in the required position at the top and bottom of the runway.

3. The door control solenoid has to be energised when the mixer door is required in the open position.

It is advisable to mount the starters away from the machine on supports free from vibration.

4. **IMPORTANT NOTICE:** All work on plant electrics including control panel circuits to be under taken by a suitably qualified and competent electrical person. All wiring in exposed positions should be suitably protected or armoured cable and protected by a suitable earth leakage circuit breaker.
5. The Mixing Star Drive and Pan Drive should be interconnected in order to start in the following sequence:-

**Mixing Star Motor
Pan Drive Motor**

6. When a Whirler is fitted the sequence should be:-
**Whirler Motor
Mixing Star Motor
Pan Drive Motor**

RP550XD TYPICAL LAYOUT OF STARTERS

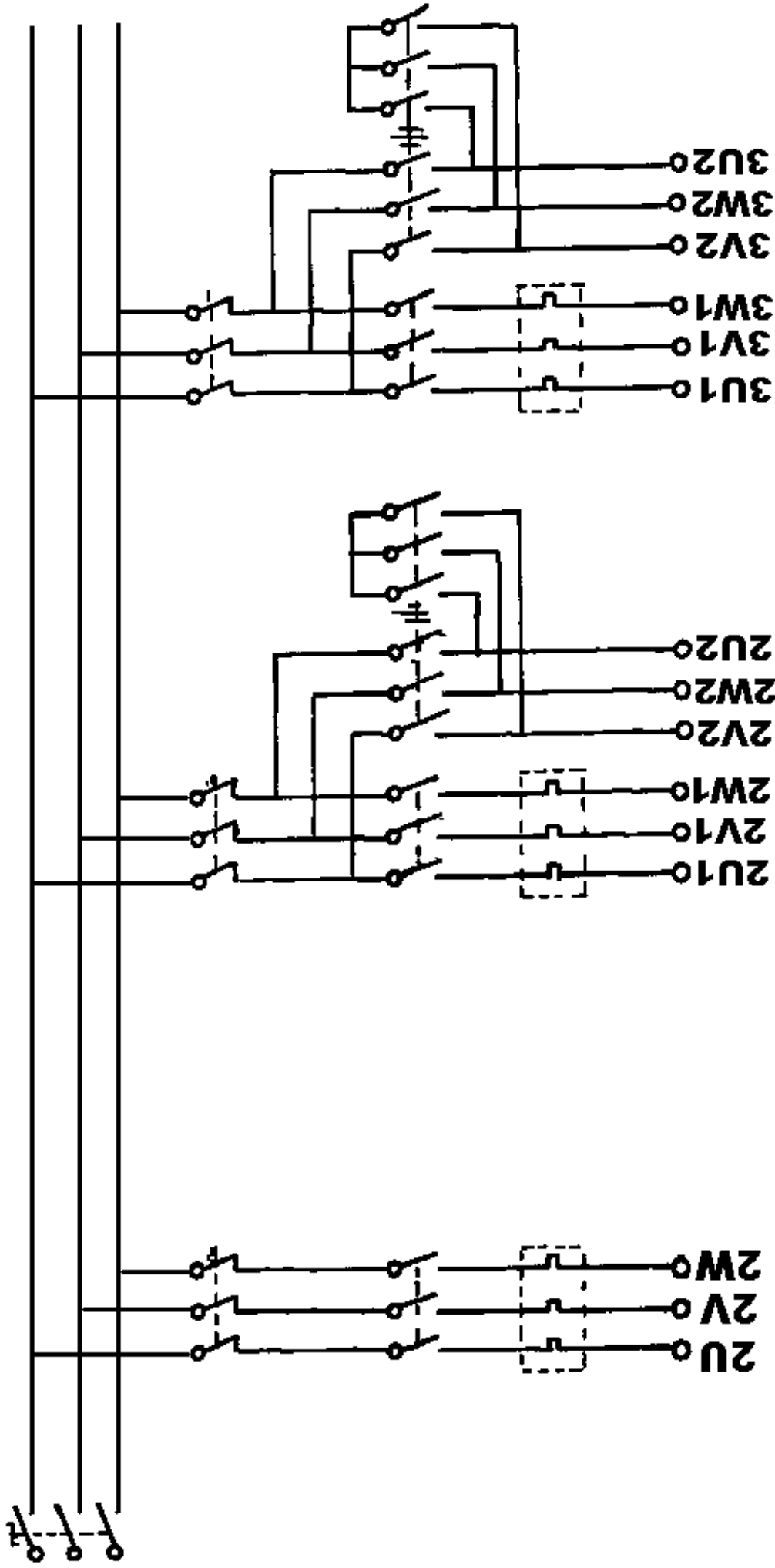

2.2KW PAN DRIVE

11KW STAR DRIVE

15KW WHIRLER

RP550XD WINCH MOTOR BRAKE WIRING

FLENDER MOTORS ABOVE 4KW

BRAKE WIRED ACROSS MOTOR 6 PIN TERMINAL BLOCK

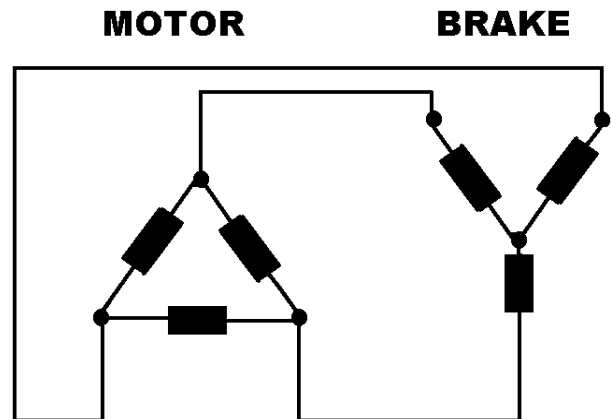
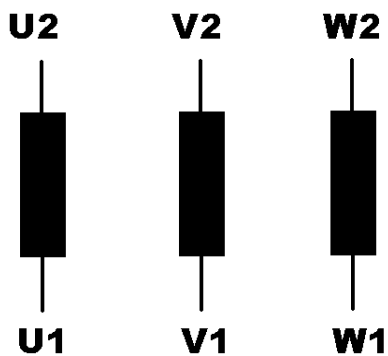
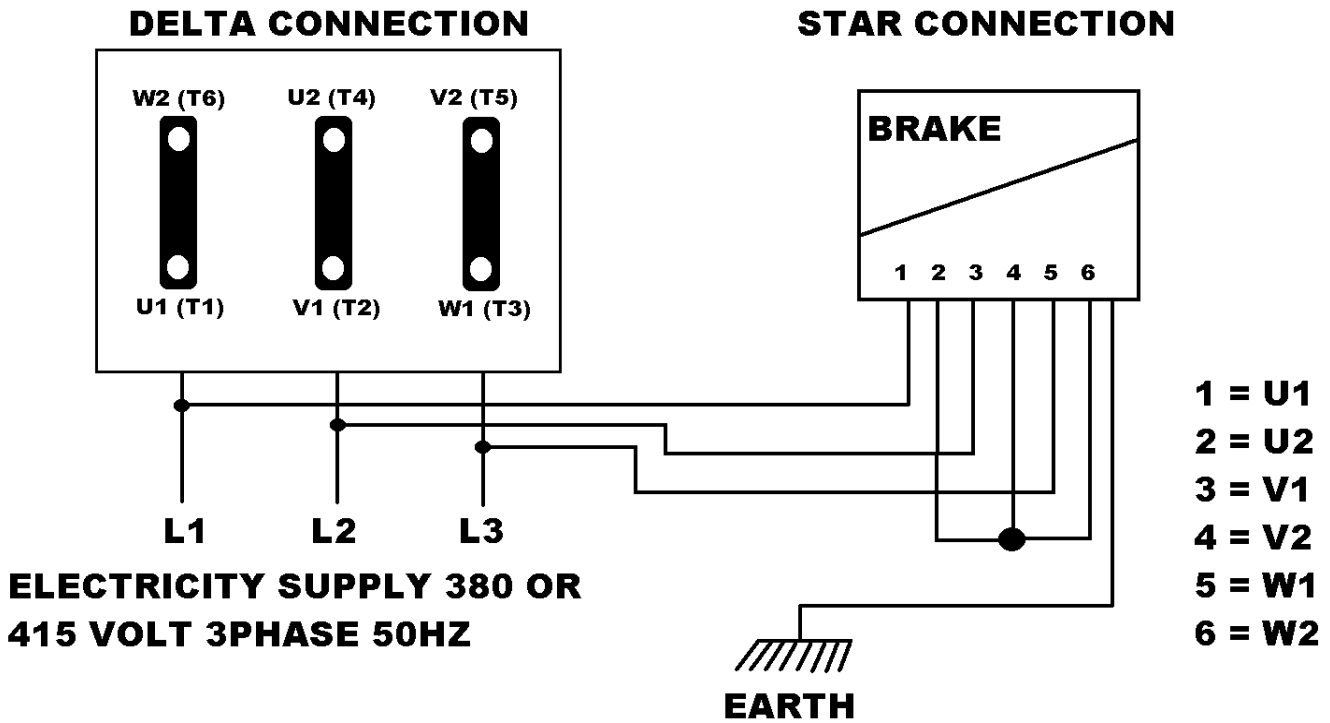

THREE PHASE A.C. BRAKE CONNECTED
ACROSS MOTOR TERMINALS. DIRECT-ON
- LINE STARTING METHOD ONLY

RP550XD WINCH MOTOR BRAKE WIRING

FLENDER THREE PHASE BRAKE SEPARATELY SWITCHED (9 PIN TERMINAL BLOCK)

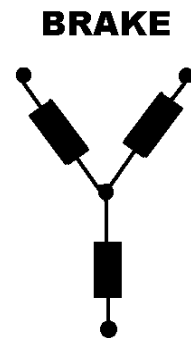
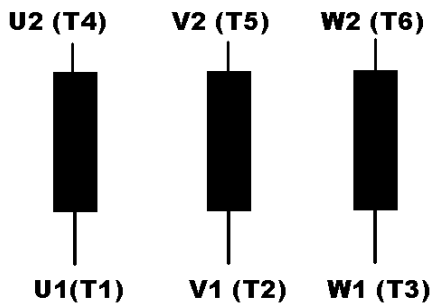
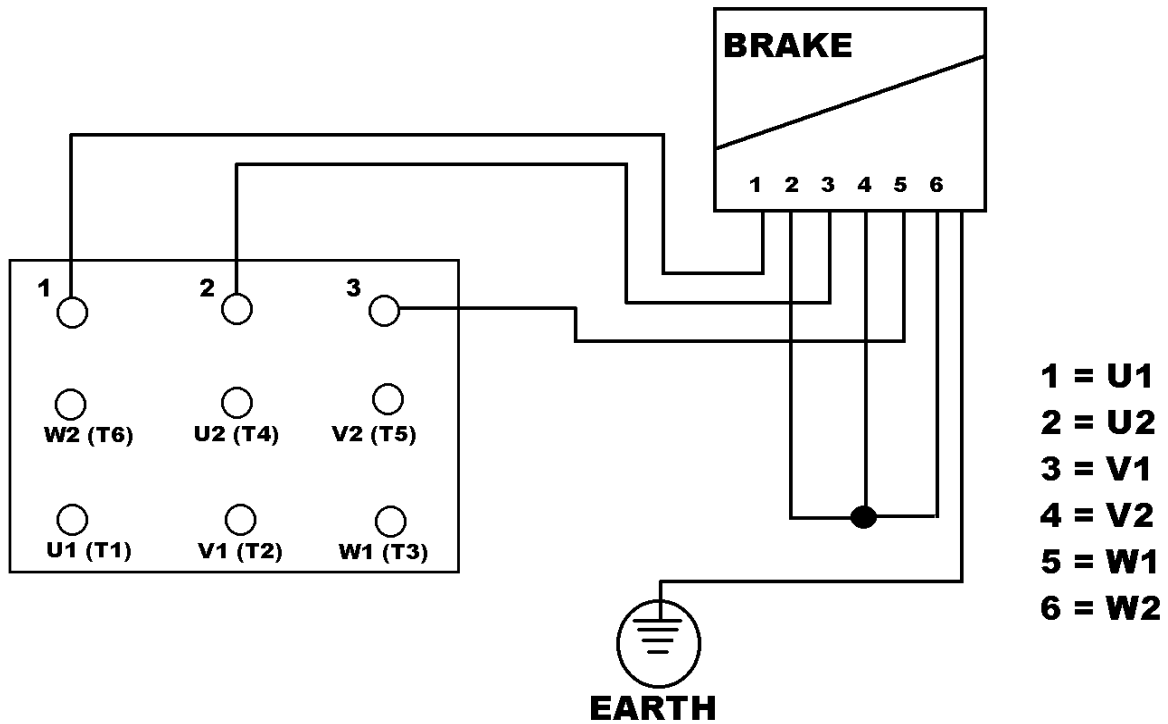

MOTOR CONNECTIONS

UP TO AND INCLUDING 4.0KW DIRECT ON LINE
STARTING

LINK W2 TO U2
LINK U2 TO V2

ABOVE 4.0KW DIRECT ON STARTING

LINK W2 TO U1
LINK U2 TO V1
LINK V2 TO W1

ABOVE 4.0KW STAR DELTA STARTING

NO LINKING

RP550XD FLENDER MOTOR WIRING DIAGRAM

MOTORS UPTO & INCLUDING 4.0Kw

SEE SEPARATE PAGE FOR MOTORS

5.5Kw AND ABOVE

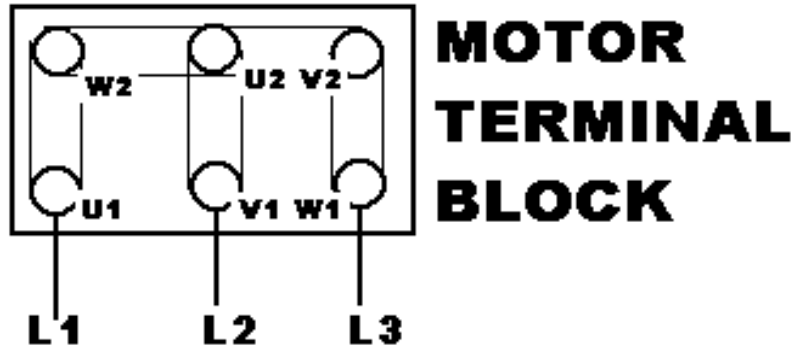

**TO REVERSE DIRECTION
OF ROTATION CHANGE
OVER ANY TWO SUPPLY
LEADS**

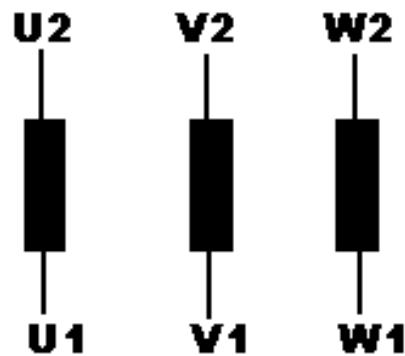

<u>SUPPLY</u>	<u>METHOD OF START</u>	<u>CONNECTION STAR</u>	<u>LINK</u>
415/3/50	DIRECT ON LINE		W2-U1
380/3/50			U2-V1
			V2-W1

UPTO & INC 4.0Kw

RP550XD FLENDER MOTOR WIRING DIAGRAM

MOTORS 5.5Kw AND ABOVE ONLY

SEE SEPARATE PAGE FOR MOTORS

4.0Kw & BELOW

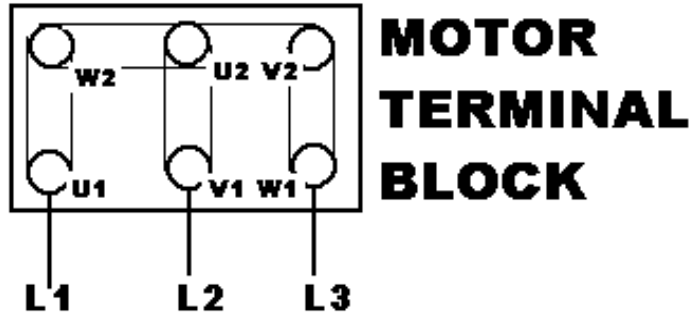

**MOTOR
TERMINAL
BLOCK**

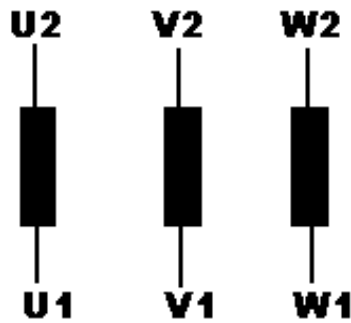

**TO REVERSE DIRECTION
OF ROTATION CHANGE
OVER ANY TWO SUPPLY
LEADS**

**STAR DELTA STARTING
NO LINKING REQUIRED**

<u>SUPPLY</u>	<u>METHOD OF START</u>	<u>CONNECTION DELTA</u>	<u>LINK</u>
415/3/50 380/3/50	DIRECT ON LINE		W2-U1 U2-V1 V2-W1

5.5Kw & ABOVE

PAGE INTENTIONALLY BLANK

PAGE INTENTIONALLY BLANK

INTERLOCK DOOR MECHANISM

NOTE SUPPLY WITH FOLLOWING ITEMS

1. KEY STANDARD MLK100
2. DUST CAP MLM100

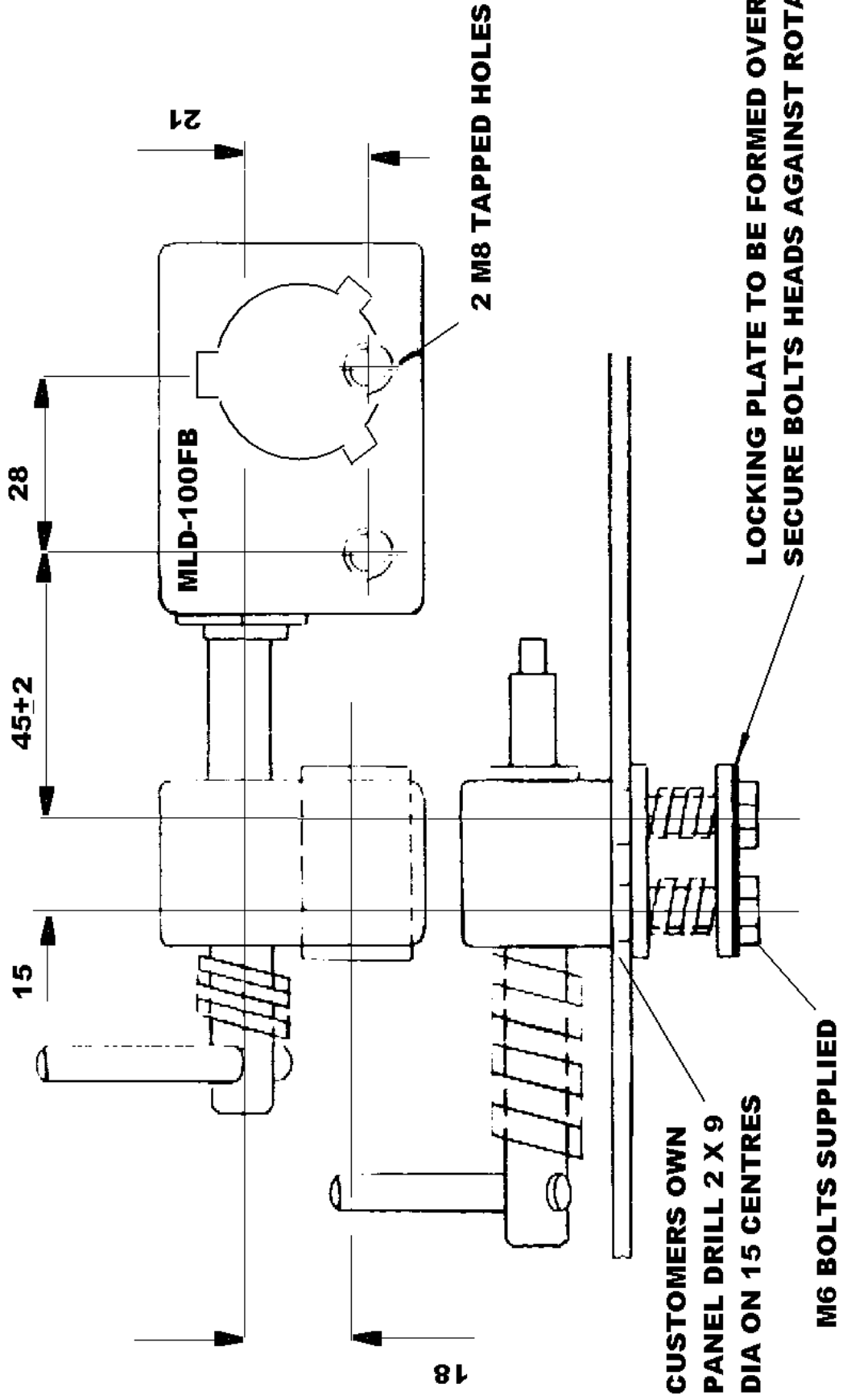

MISTURA DOOR INTERLOCK MECHANISM

1	CR719072	Interlock Door MLD100FB	A/R
2	CR229093	Key MLK100A Code A	A/R
2A	CR229094	Key MLK100B Code B	A/R
2B	CR229124	Key MLK100C Code C	A/R
3	CR229125	Cap Dust MLM100	A/R

When ordering replacement keys quote code off Interlock Mechanism

**OPERATING
AND
MAINTENANCE MANUAL**

SECTION 7

PNEUMATIC SYSTEM

SHUTDOWN PROCEDURE – PNEUMATICS

(This procedure to be read in conjunction with electrical procedure – see section six).

We Recommend

A lockable dump valve be fitted in the feed line to our mixing equipment (see drawing below).

Prior to any maintenance, the mixing equipment must be isolated using the above padlockable shut off valve. When put to the dump position, air will be allowed to vent to atmosphere removing the potential stored energy hazard. With the system in this condition, the mixer door will open and discharge blade will lower.

Important

Prior to entry into mixing pan, the air supply must be exhausted and isolated as above. Check door is fully open and the discharge blade rests upon pan base before commencing maintenance/cleaning. Also check that the pressure gauge reads zero.

Should blade or door remain up or partially closed, it is imperative that the cause is investigated and dealt with prior to entering mixing pan. See maintenance section.

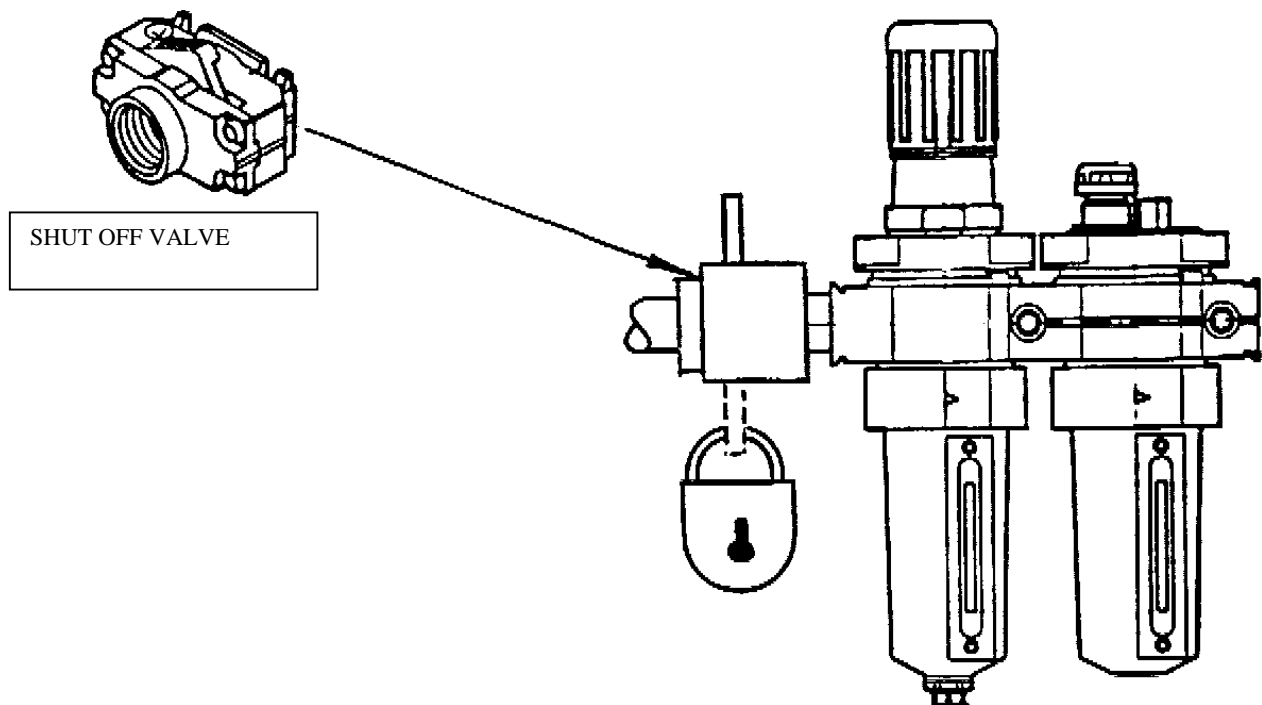

RP550XD 110 VOLT PNEUMATIC CIRCUIT

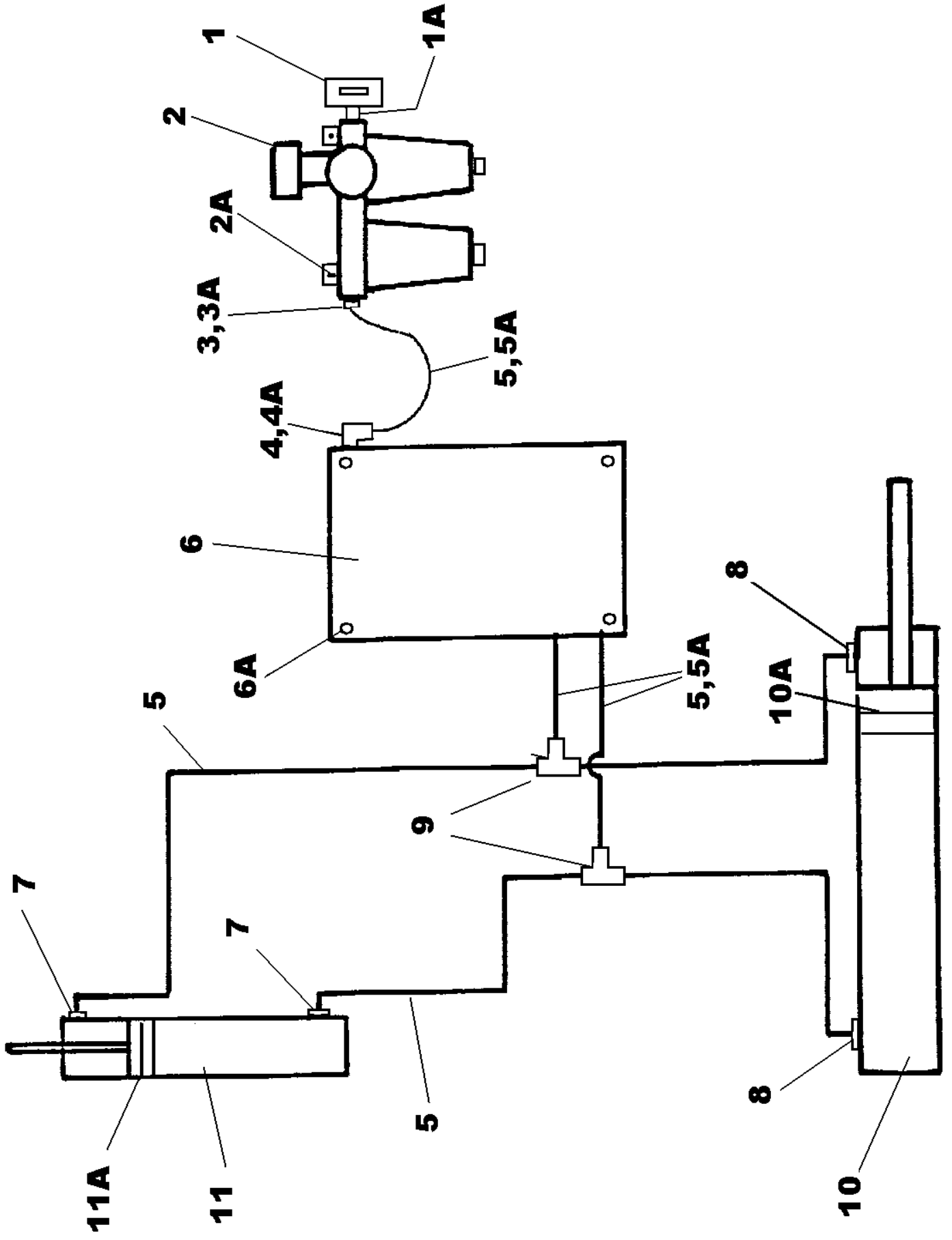

RP550XD 110 VOLT PNEUMATIC CIRCUIT

1	CR119347	Shut Off Valve	1
1A	191S03	1/2"-1/2" BSP Male/Male Nipple Adaptor Tapered	1
2	CR110005	Air Service Unit/Regulator/Lubricator	1
2A	11S03C	Screw Set Air Unit/Regulator Retaining	4
2B	267S05	Washer Flat	8
2C	17S04	Washer Spring	4
2D	7S03	Nut	4

Available spares for Air Service Unit itemised below:-

*	CR119373	Bowl Regulator	1
*	CR119374	Bowl Lubricator	1
*	CR119375	Filter Repair Kit	1
*	CR119376	Filter Element	1
*	CR119377	Lubricator Repair Kit	1
*	CR119378	Gauge Pressure	1
*	CR119379	Bracket Mounting	2
*	CR119380	Knob Regulator	1

3	CR119261	1/2" BSP Male x 12mm Fem Push In Straight Adaptor	1
4	CR119265	1/2" BSP Male x 12mm Female Push In Elbow	1
5	CR119119	12mm Diameter Plastic Air Hose	A/R

Items 3A,4A & 5A are used if 8mm Air Hose is fitted between Regulator, Control Box & T Pieces

3A	CR119208	M12 Female-M8 Female Straight Push In Reducer	1
4A	CR119208	M12 Female-M8 Female Straight Push In Reducer	1
5A	CR119133	8mm Diameter Plastic Air Hose	A/R

6	CR119190	Electric/Pneumatic Solenoid Control Box Single Acting 110 Volt	1
6A	CR119240	Electric/Pneumatic Solenoid Control Box Double Acting 110 Volt	1
6B	11S03C	Screw Set Control Box Retaining	4
6C	267S05	Washer Flat	8
6D	17S04	Washer Spring	4
6E	7S03	Nut	4

7	CR119264	3/8" BSP Male x 12mm Female Push In Elbow, Discharge Blade Cylinder, both ends	2
---	----------	--	---

7A	CR119129	Alternative 3/8" BSP Male x 12mm Female Push In Straight Adaptor for Bottom End of Discharge Blade Cylinder, if required	
----	----------	--	--

8	CR119265	1/2" BSP Male x 12mm Female Push In Elbow, Discharge Door Cylinder, both ends	2
---	----------	---	---

8A	CR119261	Alternative 1/2" BSP Male x 12mm Female Push In Straight Adaptor for Discharge Door Cylinder, both ends	2
----	----------	---	---

9	CR119267	12mm Tee Plastic Push In	2
10	CR110303	Pneumatic Cylinder Discharge Door	1
10A	CR110326	Seal Kit For Item 10	1
11	CR110304	Pneumatic Cylinder Discharge Blade	1
11A	CR110323	Seal Kit For Item 11	1

RP550XD 110 VOLT PNEUMATIC CIRCUIT

12	V2003253	Cable Tie Nylon Long (not illustrated)	A/R
13	V2003111	Cable Tie Nylon short (not illustrated)	A/R
14	CR119215	M12 Female- M12 Male Push In Elbow, if required	A/R

The following alternative items are used to reduce from 12mm diameter Air Hose to 8mm diameter Air Hose if required

CR119208	M12 Male - M8 Female Straight Push In Reducer	A/R
CR119133	8mm Diameter Plastic Air Hose	A/R

**OPERATING
AND
MAINTENANCE MANUAL**

SECTION 8

MISCELLANEOUS

MISCELLANEOUS

8.1 NOISE DETAILS

Measured in accordance with Directive 79/113EEC at four points around the machine at 1 metre radius and at a height of 1 metre the noise did not exceed 85LPA

RP550XD PAN COVER FOR LOADER

1	CR049011	Pan Cover Assembly with Swinging Lid Used With Loader	1
Comprises of following items			
2	11S03A	Screw Set Cover Retaining M8 x 16	6
2A	11S03B	Screw Set Cover Retaining M8 x 20	2
3	17S04	Washer Spring M8	3
4	267S05	Washer Flat M8	4
5	CR049012	Cover	1
6	CR059002	Door Swinging	1
7	CR059003	Counterbalance Weight	2
8	54S07M	Pin Roll	2
9	8S05P	Bolt M12 x 100	2
10	267S07	Washer Flat M12	4
11	61S05	Nut Binx M12	2

PAGE INTENTIONALLY BLANK

PAGE INTENTIONALLY BLANK

PAGE INTENTIONALLY BLANK

**OPERATING
AND
MAINTENANCE MANUAL**

SECTION 9

**ELECTRONIC LOADCELL & INDICATOR/
READOUT BOX**

SPECIFICATIONS

Power Requirements:	115 VAC 60 Hz (optional 230 VAC 50/60 Hz) powering a 12 VDC 300 mA wall plug-in UL/CSA listed power supply for the Desktop enclosure. 115 VAC 60 Hz (optional 230 VAC 50/60 Hz) at 0.1A for the NEMA 4X enclosure.
Battery Operation:	12 VDC input jack for operation from an external battery 12 volt, 1.6 Ah for 8 hours operation
Enclosure Size:	Desktop: 8.65" W x 6.5" H x 3" D NEMA 4X: 9.8" W x 7.3" H x 3.2" D
Operating Temperature:	14° to 104° F or -10° to +40° C
Display:	5-digit, 0.6" high, 7-segment red LED
Sensitivity:	0.7uV/graduation (0-3.3 mV/V), Class III
Signal Input Range:	1.0mV min. to 50 mV max.
Transducer Excitation:	8.0 VDC
Number of Load Cells:	8 each, 350 OHM minimum load cells
Load Cell Cable Length:	150' max.; 30' max w/o sense lines
Resolution:	1 part in 20,000 displayed - 1 part in 80,000 internal
Capacities:	1,000 to 10,000 divisions commercial Up to 99,999 divisions noncommercial
Graduation Value:	1, 2 or 5 x 1, 0.1, 0.01 or 0.001
Sample Rate:	1 to 12 samples per second selectable
Auto Zero Range:	0.5 or 1 through 9 graduations
Weighing Units:	Pounds, kilograms, ounces, grams or pounds/kilograms
Keyboard:	Membrane type with 21 keys

STANDARD FEATURES:

- Keyboard or Push Button Tare
- Gross, Tare, Net Conversion
- Metric Conversion
- Bi-directional Serial Interface
- Dual Preset Weight Comparator or Checkweigher with Outputs
- Auto Shut-Off Feature
- Selectable Sleep Mode
- Selectable Filtering
- Selectable Automatic Power On

OPTIONAL FEATURES:

- NEMA 4X Enclosure
- External Relay Box for Preset Weight Comparators or Checkweigher (desktop only)
- Internal Relay Board for Preset Weight Comparators or Checkweigher (NEMA 4X only)

INSTALLATION

The Model 708 Weight Indicating Instrument is available in either a stainless steel desktop enclosure or a stainless steel NEMA 4X wall-mount enclosure. Determine which enclosure version you have and refer to the appropriate section for installation and interconnection.

AUTO-ON

The AUTO-ON jumper J1, when connected, will cause the indicator to power on automatically whenever power is applied to the power input connector. If power is lost momentarily and then reapplied, the indicator will turn on without pressing the ON key. See Figure No. 9 for location.

INTERNATIONAL/ DOMESTIC JUMPER (J14Int)

Install the International/Domestic jumper, J14, to comply with OIML requirements (see Figure No. 9). With J14 installed, the 708 will perform the following functions:

1. A "lamp test" will be performed on power-up.
2. The printout of keyboard tare will be designated as "PT."

Please note the installation precautions.

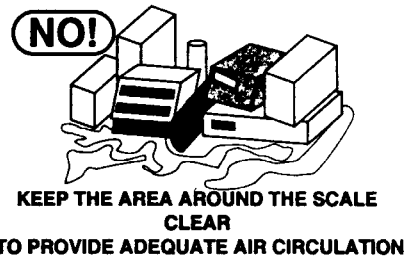
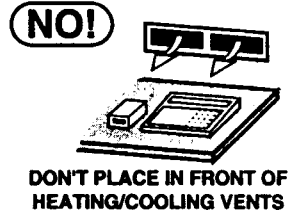
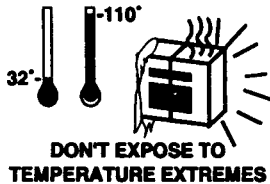

DESKTOP ENCLOSURE

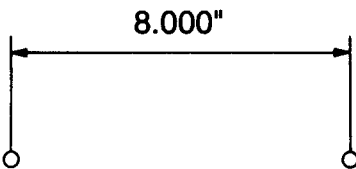

The 708 desktop enclosure may be mounted on a desktop or other smooth, flat, horizontal surface or it may be mounted on a wall. Refer to Figure No. 1 for a layout of the wall-mounting bolts. Regardless of the manner in which the 708 is installed, the location chosen should be free of temperature extremes and water. It should be in a location where the display is easily viewed and is not subject to direct sunlight. The indicator should be mounted such that it is within easy reach of the operator. If wall mounted, make certain that the structure and mounting bolts are of sufficient strength to support the 708.

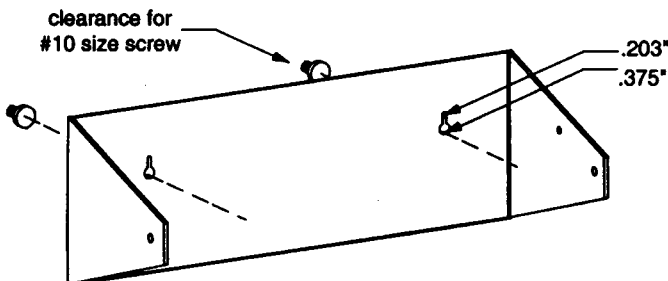

Figure No. 1

All terminations to the Model 708 Desktop Weight Indicating Instrument are made at the rear panel of the instrument. Connections for the Load Cell input, the PWC output and the Serial I/O are all made via "D" subminiature connectors while the 12VDC power is connected using a jack connector. Figure No. 2 illustrates the layout of the connector panel.

external load. When selecting the relays make certain that they are of sufficient capacity to drive the external load. A setup selection determines whether the device is on or off below the preset value. Refer to Figure No. 5 for the layout of the PWC Output connector.

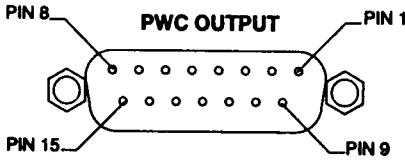

Figure No. 5

PIN NO.	FUNCTION
10	OVER/PWC1
2	UNDER/PWC2
1	ACCEPT
12	GROUND

NEMA 4X ENCLOSURES

For desk mounting of the 708 in the NEMA 4X enclosure, it is necessary to order separately a "DESK-MOUNT" kit. Refer to Assembly Instruction for Desk-Mount Kit (8539-M097-O1) for mounting instructions.

The Model 708 in a NEMA 4X enclosure is normally mounted on the wall or some other vertical surface. The enclosure is attached to the wall with four (4) bolts. Refer to Figure No. 6 for the hole layout for the NEMA 4X enclosure.

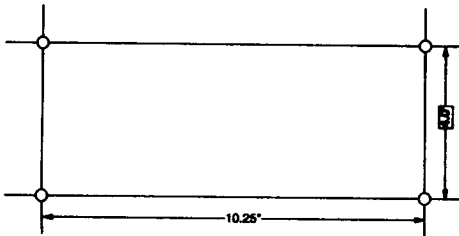
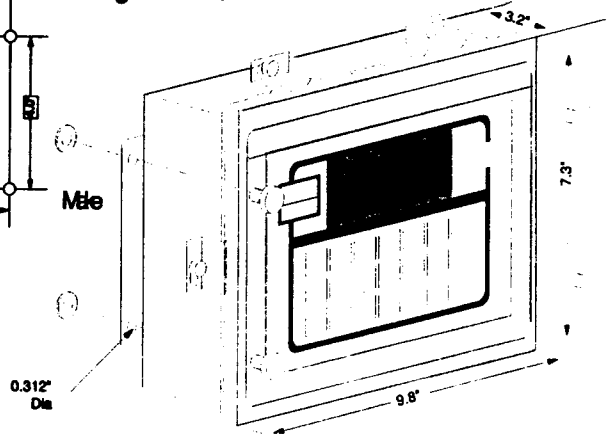

Figure No. 6



certain that the location chosen is free from sudden changes in temperature and that the mounting surface is strong enough to support the enclosure while being close enough to provide the operator with easy access to the keyboard. Carefully locate the mounting hole locations on the wall then drill and install the anchor bolts. Attached the enclosure to the wall and securely tighten the retaining bolts.

Continue installation by opening the front cover on the instrument enclosure. Loosen all four (4) retaining screws and rotate each of the clips to the side. **DO NOT REMOVE THESE SCREWS.** Fully open the front cover exposing the internal printed circuit board.

Load Cell Connection

Loosen the cable gland connector for the load cell cable. This gland connector is located on the bottom of the enclosure on the right-hand side. Refer to Figure No. 7 for an illustration of the connector layout.

Slip the single cable from the load cell or load cell junction box through the gland connector and into the enclosure. Remove 2 inches of the outer insulation jacket then remove 1/4 inch of insulation from each of the wires (either 4 or 6). Refer to Figure No. 8 for an illustration of the proper method of preparing and then connecting wires to the terminal blocks. Once the cable has been properly prepared, connect it to terminal block P4 on the main printed circuit board. Figure No. 9 shows the location of the terminal blocks on the main printed circuit board.

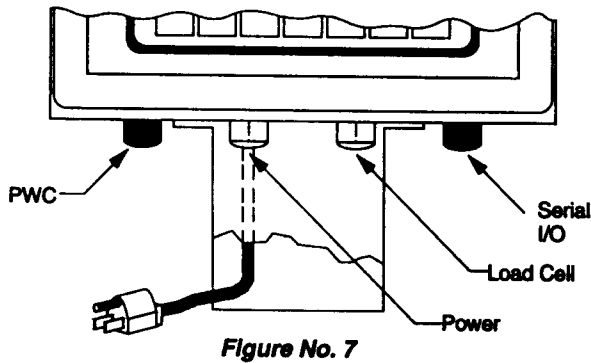

Figure No. 7

Locate the one for the load cell and connect the cable as shown. To install a wire in a terminal block, first press down on the release bar for the terminal, insert the wire into the terminal opening then release the bar locking the wire in place. Repeat this procedure until all of the wires and shield have been installed. NOTE! If the load cell cable does not contain sense leads, you must install plug-in jumpers at J2 and J3 to connect the sense inputs to the excitation leads on the PC board. If the load cell cable does contain sense leads, these jumpers must be removed and stored by placing them on one pin only.

Printer Cable Installation

Loosen the gland connector adjacent to the power cable gland connector (see Figure No. 7). Remove 2 inches of the outer insulating jacket from the cable then remove 1/4 inch of insulation from each of the wires (see Figure No. 8). These wires are to be connected to terminal block P8 at the bottom edge of the printed circuit board. Refer to Figure No. 9 for the location of this terminal block.

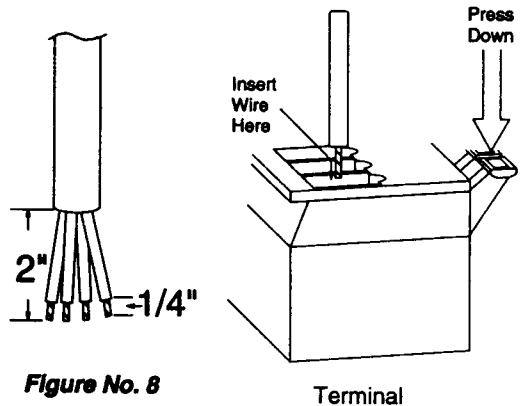

Figure No. 8

To terminate the wires, first press down on the terminal release bar then insert the wire into the terminal opening and release the bar to lock the wire in place.

Preset Weight Comparator/Checkweigher Logic Level Output

If you so choose, you may use the logic level outputs from your 708 indicator's preset weight comparators or checkweigher to control peripheral devices used to manage the flow of material or signal when the weight is within preset limits. Note that these outputs are at logic level and cannot drive external devices directly. Solid state relays can be used to accept the logic level output from the 708 and in turn drive the external device.

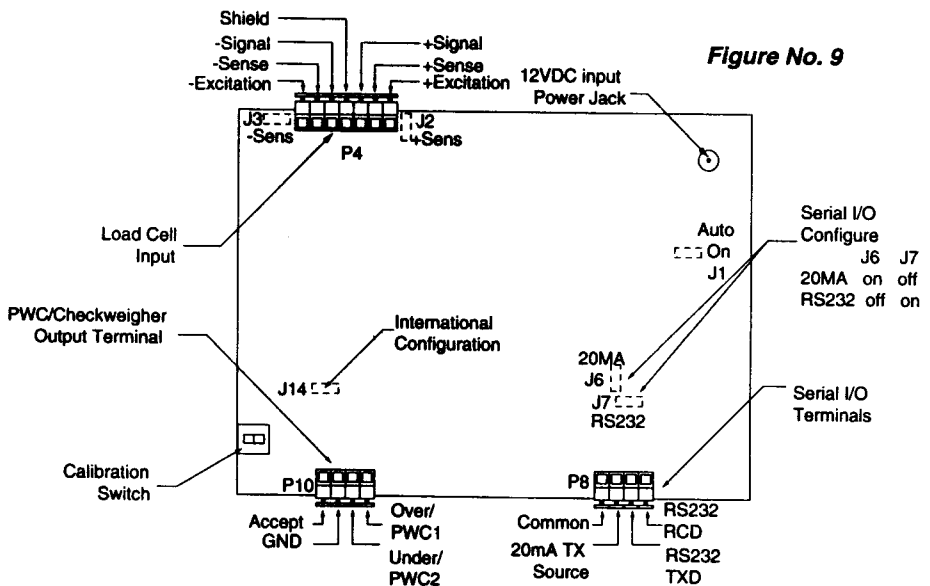



Figure No. 9

KEYPAD FUNCTIONS

The 708 is equipped with a 21-key keypad. The keypad is used to enter commands and data. This section describes each key along with the function it performs. It will be helpful to refer either to Figure No. 12 or to the actual 708 keypad while reading this section.



The membrane keyboard is not to be operated with pointed objects (pencils, pens, fingernails, etc.). Damage to keyboard resulting from this practice will **NOT** be covered under warranty.

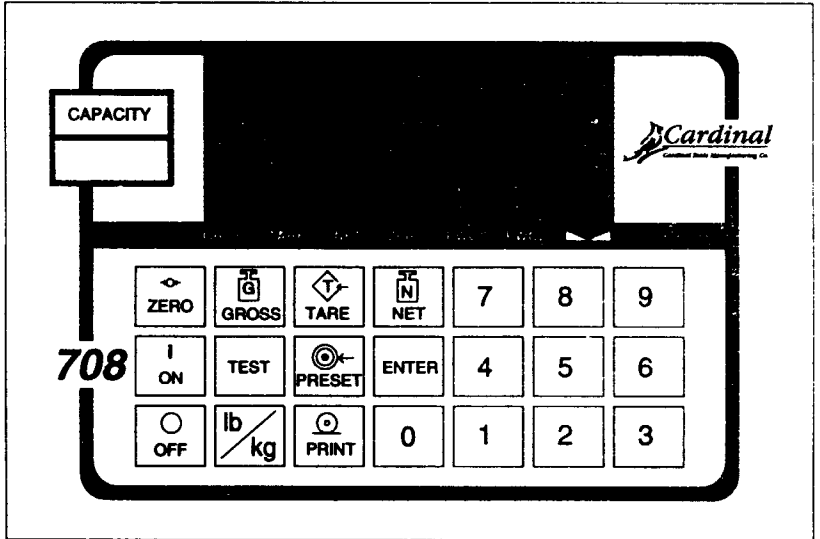

Figure No. 12

- | | |
|------------|---|
| I
ON | <p>ON KEY
Pressing this key applies power to the 708 and turns on the display.</p> |
| OFF | <p>OFF KEY
Pressing this key removes power from the 708 and turns the display off.</p> |
| ZERO | <p>ZERO KEY
This key is used to reset the gross weight to zero. If the gross weight exceeds the preset limit for this key an error message will be displayed when the key is pressed. The zero limit may be set to either 4% or 100% of scale capacity during setup and calibration of the 708.</p> |
| G
GROSS | <p>GROSS KEY
This key is used to return the weight display to the Gross Weight mode. In the gross weight mode, the total of all weight placed on the scale since the display was zeroed is displayed. The GROSS annunciator beneath the display window is turned on to signal the display of gross weight.</p> |
| T
TARE | <p>TARE KEY
This key is used to enter a tare weight of up to four (4) digits and can operate in one of two modes depending on the setup of the 708. If the push button tare feature was selected during the setup of the instrument, pressing this key will cause the 708 to enter the current gross weight as the new tare weight value and automatically enter the net weight mode. The NET annunciator will be turned on to indicate that the 708 is now displaying a net weight. If the push button tare feature was not selected, pressing the TARE key will cause the currently stored tare weight to be displayed and the TARE annunciator will be turned on. The numeric keys may be used to enter a new tare value and the ENTER key pressed to store the new value. Once the new tare value is entered the 708 will automatically enter the Net Weight mode indicated by turning on the NET annunciator.</p> |

NET KEY



Pressing this key will cause the 708 to enter the Net Weight mode where the weight displayed is the gross weight less the stored tare weight. The NET annunciator is turned on to show that the displayed weight is the net weight. Note that the 708 will only enter the Net Weight mode if a valid tare weight is currently stored.

TEST KEY



The TEST key is used to conduct a test of all display and memory elements. The test consists of 4 cycles each lasting 2 seconds:

1. All vertical display segments on (no annunciators).
2. All horizontal display segments on (no annunciators).
3. All annunciators and decimal points on.
4. All display elements off.

PRESET KEY



The PRESET key is used to enter the weight values for either the two preset weight comparators or for the checkweigher feature depending on which feature was selected during setup and calibration of the 708. If the Preset Weight Comparator feature was selected, the PWC1 annunciator will flash and the display will show the currently stored value for the number 1 preset weight comparator. If the value displayed is acceptable, press the ENTER key, otherwise, use the numeric keys to enter the new preset value and press the ENTER key. The PWC2 annunciator will now flash and the display will show the currently stored value for the number 2 preset weight comparator. As before, if the value displayed is acceptable, press the ENTER key, otherwise, use the numeric keys to enter the new value and press the ENTER key. If the Checkweigher feature was selected and the PRESET key pressed, the ACCEPT and UNDER annunciators will flash and the preset value for the minimum acceptable weight will be displayed. Press the ENTER key if the displayed value is correct or use the numeric keys and enter the new value and press the ENTER key. The ACCEPT and OVER annunciators will now flash and the display will show the minimum value of weight over the accepted range. As before, if the value shown is correct, press the ENTER key. If the value is incorrect, enter the new value and press the ENTER key to save it. Note that this value must be greater than the accept value. Remember that both the preset weight comparators and checkweigher functions operate on the absolute value of the weight ignoring the polarity. After the second preset value is entered, the 708 will return to normal operation.

lb / kg KEY

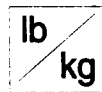

Pressing this key will change the weighing units to the alternate units of measurement if selected during setup of the instrument. With pounds displayed (lb annunciator turned on) pressing this key will change the weighing units to kilograms (kg annunciator turned on). Note that this feature must be enabled during setup and calibration for this key to be operational.

PRINT KEY



Pressing this key will initiate the transmission of weight data via the serial I/O port unless the continuous data output feature was enabled during setup and calibration or setup review. Note that if the continuous data output feature was selected, this key will be disabled.

ENTER KEY



The ENTER key serves two purposes. First, when reviewing setup parameters, pressing the ENTER key will cause the current setting of the parameter to be displayed. Second, the ENTER key is used to signal the completion of the entry of data and causes the 708 to process the data entered.

0 THROUGH 9 KEYS

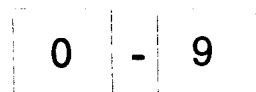

These keys are used to enter numeric data during the setup and calibration as well as during normal operation of the instrument.

ANNUNCIATORS

Note that annunciators are turned on to indicate that the display is in the mode corresponding to the annunciator label or that the status indicated by the label is active. Some annunciators are flashed on and off to signal that the 708 is waiting for an input from the keypad for use by the feature indicated by the annunciator.

ZERO

The ZERO annunciator is turned on to indicate that the weight is within +/- 1/4 division of the center of zero.

GROSS

The GROSS annunciator is turned on to indicate that the displayed weight is the gross weight which is the total of all weight placed on the scale platform since the display was last reset to zero.

TARE

The TARE annunciator is flashed on and off to show that the 708 is in the tare weight input mode and that the new tare weight value should be entered on the numeric keys.

NET

The NET annunciator is turned on to show that the displayed weight is the net weight which is the gross weight less the tare weight.

PWC1

The PWC1 annunciator is turned on to indicate that the displayed weight is equal to or greater than the weight value stored as preset number 1. Note that this annunciator is active only when the Preset Weight Comparator feature has been enabled.

PWC2

The PWC2 annunciator is turned on to indicate that the displayed weight is equal to or greater than the weight value stored as preset number 2. Note that this annunciator is active only when the Preset Weight Comparator feature has been enabled.

STABLE

The STABLE annunciator is identified with two small triangular shapes and is turned on when the weight display is stable. This means that the change in successive weight samples is less than the motion limits selected during setup and calibration of the 708.

UNDER

The UNDER annunciator is located to the left of the weight display and is used to signal that the displayed weight is less than the minimum value of acceptable weight used in the Checkweigher feature. Note that this annunciator is active only when the Checkweigher feature is enabled.

ACCEPT

The ACCEPT annunciator is located just above the weight display and is used to signal that the displayed weight is within the acceptable weight limits for the Checkweigher feature. That is, it is equal to or greater than the minimum acceptable weight and equal to or less than the maximum acceptable weight. Note that this annunciator is active only when the Checkweigher feature has been enabled.

OVER

The OVER annunciator is located to the right of the weight display and is used to signal that the displayed weight is equal to or greater than the minimum value of over weight used in the Checkweigher feature. Note that this annunciator is active only when the Checkweigher feature has been enabled.

lb

The lb annunciator is located to the right of the weight display and is turned on to show that the displayed weight units of measure is pounds.

kg

The kg annunciator is located to the right of the weight display and is used to signal that the units of measurement for the displayed weight is kilograms.

ERROR CODES

The 708 is equipped with software that detects when an error in operation takes place. The following lists the error code displays supported by the 708 along with their meaning. Should you encounter an error display, please refer to this list for the cause and corrective action.

UnSt

Motion is present when trying to power up, print, zero or perform a push button tare function. **CORRECTIVE ACTION:** wait for a stable weight display (STABLE annunciator on) before performing these operations.

UnLd

The weight on the scale exceeds the zero range when powering up. **CORRECTIVE ACTION:** remove the excess load from the scale then press the ZERO key. If the scale has not been calibrated previously, calibration should be completed before attempting further operation.

LoAd

The scale deadload is less than the zero range when powering up. **CORRECTIVE ACTION:** replace the scale platform or items normally on the scale when it was calibrated and press the ZERO key. If the scale has not been calibrated previously, calibration should be completed before attempting further operation.

-oF-

The 708 is attempting to display a positive number greater than 5 digits in length or a negative number of more than 4 digits. **CORRECTIVE ACTION:** return to the Gross Weight mode and review the Tare value.

-oL-

The load on the scale exceeds the scale capacity plus 9 divisions. **CORRECTIVE ACTION:** remove the over capacity load from the scale platform.

Err

An invalid keypad entry was attempted:

1. PRINT key pressed with a negative weight displayed.
2. TARE key pressed to enter a push button tare value of zero or a negative value.
3. ENTER key pressed to enter a tare weight value that exceeds scale capacity.
4. ENTER key pressed to enter a tare weight value that is inconsistent with the scale's division value. (i.e. attempt to enter a tare value of 123 with scale division value of 5).
5. ZERO key pressed when the gross weight is outside the scale zero weight range.
6. lb/kg key pressed to change to kilograms when the kilogram tare weight value exceeds 4 digits in length.

CORRECTIVE ACTION: determine which of the reasons for the error display is applicable then take the appropriate corrective action.

ErrA

The proper load cell signal is not getting to the signal processing circuit for one or more of the following possible reasons with corrective action:

The load cell output is below the indicator minimum input of 1.0mV. Consult your scale serviceman;

Sense lead jumpers are not installed for four (4) wire load cells. Install both SENS jumpers (see Figure No. 9);

The load cell wiring is incorrect. Check load cell connector wiring;

Load cell or circuit failure. Consult your scale serviceman.

Err1

A program checksum mismatch has been detected.
CORRECTIVE ACTION: contact your scale serviceman.

Err2

A write command to the NOVRAM was attempted while the NOVRAM was in a protected mode (loss of control by program). CORRECTIVE ACTION: contact your scale serviceman.

Err3

RAM test failure. CORRECTIVE ACTION: contact your scale serviceman.

Err4

NOVRAM failure during startup. CORRECTIVE ACTION: contact your scale serviceman.

Err5

NOVRAM response failure. CORRECTIVE ACTION: contact your scale serviceman.

MAINTENANCE

The maintenance on the Model 708 Weight Indicating Instrument should be limited to an occasional cleaning of the outside of the instrument enclosure. There are no user-serviceable components within the enclosure. To clean the enclosure and keyboard, use a soft cloth dampened with water. If you wish to use a detergent, make certain that it is safe and then use it sparingly. Do not wash the Desktop enclosure. Only the NEMA 4X version of the 708 may be washed down.

PERFORMANCE SPECIFICATIONS

Parameter

Rated Output	mV/V \pm 0.25%
Combined Error	%*
Non-repeatability	%*
Creep (30 minutes)	%*
Temperature Effect on Zero Balance	%* / °C
Temperature Effect on Span	%* / °C
Compensated Temperature Range	°C
Operating Temperature Range	°C
Safe Overload	%*
Ultimate Overload	%*
Zero Balance	%*
Input Resistance	$\Omega \pm 30$
Output Resistance	$\Omega \pm 1.5$
Insulation Resistance	M Ω @ 100 V
Recommended Supply Voltage	V
Maximum Supply Voltage	V

Units

mV/V \pm 0.25%
%*
%*
%*
%* / °C
%* / °C
°C
°C
%*
%*
%*
$\Omega \pm 30$
$\Omega \pm 1.5$
M Ω @ 100 V
V
V

LOAD CELL CAPACITY

≤ 7500 kg

≥ 10000 kg

2	2
< \pm 0.05	< \pm 0.1
< \pm 0.025	< \pm 0.03
< \pm 0.05	< \pm 0.05
< \pm 0.0025	< \pm 0.0025
< \pm 0.008	< \pm 0.008
-10 to +40	-10 to +40
-40 to +80	-40 to +80
150	150
300	300
< \pm 1	< \pm 1
380	380
350	350
> 5000	> 5000
10	10
15	15

* WITH RESPECT TO RATED OUTPUT

CABLE SPECIFICATIONS

4 m - Four core screened, 6mm dia. with polyurethane outer sheath

POSITIVE EXCITATION = RED
NEGATIVE EXCITATION = BLUE

POSITIVE SIGNAL = GREEN
NEGATIVE SIGNAL = YELLOW

PHYSICAL DIMENSIONS (mm)

RANGE (kg)	A	B	C	D	E	F	G	H	J	K	L	M	Wt (kg)	Wt (kg)
500	125	84	42	42	13	M16 x 2	102	174	16	193	40	135	3	13.6
1000 to 7500	125	84	42	42	13	M24 x 2	102	174	16	193	40	135	3.6	13.6
10000 / 15000	175	110	55	64	21	none	148	238	21	243	48	175	8.8	22.5
20000 to 30000	175	110	55	64	27	none	148	238	21	243	50	175	9.3	23.6

(Cell)

(LA90)

